

**REVISED 2016**



**ADVANCED  
ENGINE PERFORMANCE  
SPECIALIST TEST (L1)**

**COMPOSITE VEHICLE TYPE 4  
REFERENCE BOOKLET**

*This booklet is intended only for reference when preparing for and taking the ASE Advanced Engine Performance Specialist Test. The composite vehicle type 4 powertrain control system is based on designs common to many vehicle manufacturers, but is not identical to any actual production vehicle.*

# Table of Contents

<b>INTRODUCTION</b> .....	<b>4</b>
<b>POWERTRAIN</b> .....	<b>4</b>
ENGINE.....	4
TRANSMISSION .....	4
<b>CONTROL MODULES</b> .....	<b>4</b>
ENGINE CONTROL MODULE (ECM).....	4
FUEL PUMP CONTROL MODULE (FPCM).....	5
TRANSMISSION CONTROL MODULE (TCM) .....	5
INSTRUMENT CLUSTER MODULE (ICM).....	5
IMMOBILIZER MODULE .....	5
<b>SYSTEMS</b> .....	<b>6</b>
ELECTRONIC THROTTLE CONTROL SYSTEM .....	6
EXHAUST SYSTEM.....	6
FUEL DELIVERY SYSTEM .....	6
IGNITION SYSTEM.....	7
IMMOBILIZER ANTI-THEFT SYSTEM.....	7
ON-BOARD REFUELING VAPOR RECOVERY (ORVR) EVAP SYSTEM .....	7
FUEL INJECTION SYSTEM.....	8
VARIABLE VALVE LIFT CONTROL SYSTEM.....	9
VARIABLE VALVE TIMING SYSTEM.....	9
<b>INPUTS - SENSORS</b> .....	<b>10</b>
ACCELERATOR PEDAL POSITION (APP 1 AND APP 2) SENSORS.....	10
A/C PRESSURE SENSOR.....	10
A/C ON/OFF REQUEST SWITCH.....	11
AIR/FUEL RATIO SENSORS (AFRS 1/1 AND AFRS 2/1) .....	11
BRAKE PEDAL POSITION (BPP) SWITCH.....	11
CAMSHAFT POSITION SENSORS (CMP 1 AND CMP 2) .....	12
CRANKSHAFT POSITION (CKP) SENSOR .....	12
EGR VALVE POSITION SENSOR .....	13
FUEL LEVEL SENSOR .....	13
FUEL PRESSURE (FP) SENSOR.....	14
FUEL TANK (EVAP) PRESSURE SENSOR.....	14
KNOCK SENSORS .....	14
HEATED OXYGEN SENSOR (HO2S 1/2 and HO2S 2/2).....	15
IGNITION SWITCH .....	15
MANIFOLD ABSOLUTE PRESSURE (MAP) SENSOR.....	15
MASS AIRFLOW (MAF) SENSOR .....	16
THROTTLE POSITION (TP 1 AND TP 2) SENSORS .....	16

TEMPERATURE SENSORS .....	17
TRANSMISSION RANGE (TR) SWITCH .....	18
TRANSMISSION TURBINE SHAFT SPEED (TSS) SENSOR .....	18
VARIABLE VALVE LIFT SYSTEM SENSORS.....	18
VEHICLE SPEED SENSOR (VSS) .....	18
<b>OUTPUTS - ACTUATORS .....</b>	<b>19</b>
CAMSHAFT POSITION ACTUATOR CONTROL SOLENOIDS .....	19
EVAPORATIVE EMISSION (EVAP) CANISTER PURGE SOLENOID .....	19
EVAPORATIVE EMISSION (EVAP) CANISTER VENT SOLENOID .....	19
EXHAUST GAS RECIRCULATION (EGR) VALVE.....	19
FAN CONTROL (FC) RELAY.....	19
FUEL INJECTORS .....	19
GENERATOR .....	19
IGNITION COILS .....	20
MALFUNCTION INDICATOR LAMP (MIL) .....	20
STARTER RELAY.....	20
THROTTLE ACTUATOR CONTROL (TAC) MOTOR .....	20
TRANSMISSION SOLENOIDS .....	20
VARIABLE VALVE LIFT MOTORS .....	21
<b>OBD SYSTEM OPERATION.....</b>	<b>22</b>
DATA COMMUNICATION .....	22
SYSTEM MONITORS.....	23
MONITOR READINESS STATUS .....	25
WARM UP CYCLE .....	25
TRIP.....	25
DRIVE CYCLE.....	25
FREEZE FRAME DATA.....	25
STORING AND CLEARING DTCS & FREEZE FRAME DATA, TURNING MIL ON & OFF .....	26
SCAN TOOL .....	26
<b>PIN / COMPONENT CROSS REFERENCE.....</b>	<b>27</b>
<b>SCAN TOOL DATA CHART.....</b>	<b>28</b>
<b>ELECTRICAL DIAGRAM 1.....</b>	<b>30</b>
<b>ELECTRICAL DIAGRAM 2.....</b>	<b>31</b>
<b>ELECTRICAL DIAGRAM 3.....</b>	<b>32</b>
<b>ELECTRICAL DIAGRAM 4.....</b>	<b>33</b>
<b>SYSTEM CUTAWAY DRAWING.....</b>	<b>34</b>

# INTRODUCTION

This ASE Composite Vehicle Type 4 was conceived and built by technical committees of industry experts to accommodate high level diagnostic questions on the L1 test. While some aspects of this Composite Vehicle may appear similar to vehicles from a number of manufacturers, it is important to understand this vehicle is a unique design and is NOT intended to represent any specific make or model. This reference document should be used when answering questions identified as Composite Vehicle questions.

Note: All testing is performed at sea level unless otherwise indicated. The reference materials and questions for this test use terms and acronyms that are consistent with SAE standards J1930 and J2012.

## POWERTRAIN

### ENGINE

- Generic, four-stroke, V6 design.
- Equipped with four chain-driven overhead camshafts, 24 valves, hydraulic valve lifters, variable intake camshaft timing, and variable intake valve lift.

### TRANSMISSION

- 6-speed, automatic transaxle with overdrive.
- Controlled by a transmission control module (TCM).
- 3 planetary gear sets, 5 clutch packs, and a single one-way clutch.
- 6 forward gears and 1 reverse gear.
- A torque converter transmits power from the engine to the transmission and is capable of lock-up in 3rd, 4th, 5th, and 6th gears.
- Contains an electronic pressure control (EPC) solenoid, 5 shift solenoids, and a torque converter clutch solenoid.

## CONTROL MODULES

### ENGINE CONTROL MODULE (ECM)

- Calculates ignition and fuel requirements, controls engine actuators and provides inputs to other modules to provide the desired driveability, fuel economy, and emissions control.
- Receives data input from other control modules and sensors.
- Controls the vehicle's charging system.
- Receives power from the battery and ignition switch and provides a regulated 5-volt supply for most of the engine sensors.
- Engine control features include coil-on-plug ignition, mass airflow, sequential port fuel injection, variable valve timing, variable valve lift, electronic throttle actuator control (TAC), air/fuel ratio sensors, a data communications bus, a vehicle anti-theft immobilizer system, a natural vacuum leak detection EVAP system and an on-board refueling vapor recovery (ORVR) system.
- The control system software and OBD diagnostic procedures stored in the ECM can be updated using factory supplied calibration files and PC-based interface software, along with a scan tool or a reprogramming device that connects the PC to the vehicle's data link connector (DLC).
- Contains a 120  $\Omega$  terminating resistor for the data bus.

## FUEL PUMP CONTROL MODULE (FPCM)

- Communicates with the ECM over a Local Area Network (LAN).
- ECM provides a 5-volt enable signal to the FPCM to enable fuel pump operation:
  - for two seconds with the ignition switch in the RUN position.
  - when the ignition switch is in the START position.
  - when the engine speed (CKP) signal is above 100 rpm.
- FPCM changes the volume of fuel supplied by the fuel pump by varying the duty-cycle of the voltage supplied to the fuel pump.
- LOW fuel pump speed command = fuel pump supply voltage duty-cycled at 50 %.
- HIGH fuel pump speed command = fuel pump supply voltage duty-cycled at 100 %.
- HIGH fuel pump speed is commanded:
  - during key ON/engine OFF prime.
  - with the engine cranking.
  - under high engine load.
  - during operation at low charging system voltage.
- If there is a communication fault on the LAN bus, and the 5-volt enable signal is present at the FPCM, the FPCM will default to HIGH speed fuel pump operation.
- Actual fuel pump duty cycle is monitored by the FPCM and is reported by the FPCM to the ECM via the LAN bus.

ECM	OFF	LOW	HIGH
FPCM Feedback	0 %	50 %	100 %

## TRANSMISSION CONTROL MODULE (TCM)

- Provides the correct transmission outputs for desired driveability, fuel economy, and emissions control.
- Receives data input from other control modules and sensors.
- Provides data inputs to other control modules including vehicle speed and gear selection.
- Provides its own regulated 5-volt supply.
- Performs all OBD II transaxle diagnostic routines and stores transaxle DTCs.
- The control system software and OBD diagnostic procedures stored in the TCM can be updated in the same way as the ECM.
- Failures that result in a pending or confirmed DTC related to any of the following components will cause the TCM to default to fail-safe mode: transmission range switch, electronic pressure control (EPC), shift solenoids, turbine shaft speed sensor, and the vehicle speed sensor.
- The TCM will also default to fail-safe mode if it is unable to communicate with the ECM.
- When in fail-safe mode, the TCM commands maximum line pressure and turns off all transmission solenoids. The transmission then defaults to 5th gear and the torque converter clutch will be disabled.

## INSTRUMENT CLUSTER MODULE (ICM)

- Receives data input from other control modules to display engine rpm, vehicle speed, fuel level, and coolant temperature.
- Includes a Malfunction Indicator Lamp (MIL) and an immobilizer indicator.
- If the instrument cluster fails to communicate with the ECM and TCM, the MIL is continuously lit.
- Contains a 120  $\Omega$  terminating resistor for the data bus.

## IMMOBILIZER MODULE

- Communicates with the ECM.
- Provides ignition key information.
- See IMMOBILIZER ANTITHEFT SYSTEM on page 7.

# SYSTEMS

## ELECTRONIC THROTTLE CONTROL SYSTEM

- The vehicle does not have a mechanical throttle cable, a cruise control throttle actuator, or an idle air control (IAC) valve.
- Throttle opening at all engine speeds and loads is controlled directly by a throttle actuator control (TAC) motor mounted on the throttle body housing.
- Dual accelerator pedal position (APP) sensors provide input from the vehicle operator, while the actual throttle angle is determined using dual throttle position (TP) sensors.
- If one APP sensor or one TP sensor fails, the ECM will turn on the malfunction indicator lamp (MIL) and limit the maximum throttle opening to 35 %.
- If both APP sensors or both TP sensors fail, or a correlation error occurs, the ECM will turn on the MIL and disable the electronic throttle control.
- When disabled by the ECM, the electronic throttle control system will default to limp-in operation:
  - the spring-loaded throttle plate will return to a default position of 15 % throttle opening.
  - the TAC value on the scan tool will indicate 15 %.
  - it will have a fast idle speed of 1400 to 1500 rpm, with no load and all accessories off.
- Normal no load idle range is 850 to 900 rpm at 5 % to 10 % throttle opening.
- No idle relearn procedure is required after component replacement or loss of voltage to the ECM.

## EXHAUST SYSTEM

A single exhaust system that is configured using a Y-pipe that connects two front catalyts, a single downstream catalyts, and a muffler.

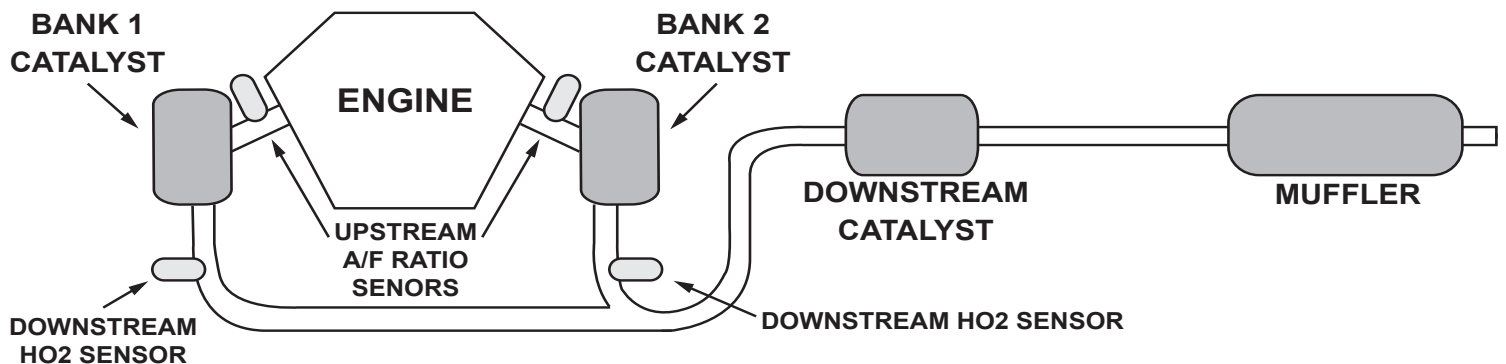

## FUEL DELIVERY SYSTEM

- Consists of an ECM, a fuel pump control module (FPCM), a fuel pressure sensor (FPS), and a fuel pump assembly.
- Sequential Multiport Fuel Injection (SFI).
- Returnless fuel supply with the electric fuel pump assembly mounted inside the fuel tank.
- Fuel pressure regulator attached to the fuel pump assembly to control fuel pressure.
- The fuel pump control module (FPCM) supplies duty-cycled, feed-side voltage to the fuel pump.
- The fuel pump control module (FPCM) provides feedback to the ECM via a LAN bus.
- Key ON/engine OFF fuel pressure = 58 to 62 psi (400 to 427 kPa).
- Fuel system pressure should be between 58 to 62 psi (400 to 427 kPa) during all operating conditions.

## **IGNITION SYSTEM**

- Distributorless Ignition (EI) with six ignition coils (coil-on-plug).
- Firing Order: 1-2-3-4-5-6
- Cylinders 1, 3, and 5 are on Bank 1; Cylinders 2, 4, and 6 are on Bank 2.
- Ignition timing is not adjustable.
- Crankshaft position (CKP) sensor input is used for base timing calculation.
- ECM controls ignition timing.
- Ignition coil drivers are integrated into the ECM.

## **IMMOBILIZER ANTI-THEFT SYSTEM**

- When the ignition switch is turned on, the immobilizer control module sends a challenge signal through the antenna around the ignition switch to the transponder chip in the ignition key. The transponder key responds with an encrypted key code. The immobilizer control module then decodes the key code and compares it to the list of registered keys.
- When the engine is started, the ECM sends a request to the immobilizer control module over the data bus to verify the key validity. If the key is valid, the immobilizer control module responds with a “valid key” message. The ECM continues normal engine operation.
- Once the engine is started with a valid key, the immobilizer system cannot cause engine shutdown.
- If an attempt is made to start the vehicle with an invalid ignition key, the immobilizer control module sends a message over the data bus to the instrument cluster to flash the anti-theft indicator lamp.
- Without a “valid key” message from the immobilizer control module within 2 seconds of engine startup, the ECM will disable the fuel injectors to kill the engine. Cycling the key off and cranking the engine again will result in engine restart and stall.
- The immobilizer control module and ECM each have their own unique internal ID numbers used to encrypt their messages, and are programmed at the factory to recognize each other. If either module is replaced, the scan tool must be used to program the replacement module, using the VIN, the date, and a factory-assigned PIN number.
- Up to eight keys can be registered in the immobilizer control module.
- Each key has its own unique internal key code.
- If only one valid key is available, or if all keys have been lost, the scan tool can be used to delete lost keys and register new keys. This procedure also requires the VIN, the date, and a factory-assigned PIN number.
- The immobilizer control module does not require a key ID relearn if battery voltage is lost.
- Neither the ECM, TCM, nor the immobilizer control module prevent operation of the starter motor for anti-theft purposes.

## **ON-BOARD REFUELING VAPOR RECOVERY (ORVR) EVAP SYSTEM**

- Causes fuel tank vapors to be directed to the EVAP charcoal canister during refueling, so that fuel vapors do not escape into the atmosphere.
- The following components have been added to the traditional EVAP system for ORVR capability: a one inch I.D. fill pipe, a one-way check valve at the bottom of the fill pipe, an ORVR vapor control valve inside the fuel tank, and a 1/2 inch I.D. vent hose from the ORVR vapor control valve to the canister.
- The ORVR vapor control valve has a float that rises to seal the vent hose when the fuel tank is full. It also prevents liquid fuel from reaching the canister and blocks fuel from leaking in the event of a vehicle roll-over.



## **FUEL INJECTION SYSTEM**

- Sequential port fuel injection, single injector for each cylinder.
- Fuel injectors are located in the intake manifold ports near the intake valves.
- Fuel injectors are ground-side controlled.

### **STARTING MODE**

- When the ignition switch is turned to RUN, the ECM sends a 5-volt enable signal to the FPCM for two seconds to build pressure in the fuel system.
- If an rpm signal is not received by the ECM within two seconds, the 5-volt enable signal to the FPCM is turned OFF.
- After the two second prime, the ECM will maintain the 5-volt enable signal to the FPCM with the ignition switch in the START position, or as long as the engine speed (CKP) is 100 rpm or more.

### **CLEAR FLOOD MODE**

- During cranking, when the accelerator pedal is fully depressed (pedal position of 80 % or greater) and the engine speed is below 400 rpm, the ECM turns off the fuel injectors.

### **RUN MODES: OPEN AND CLOSED LOOP, FUEL CUT OFF**

- OPEN LOOP - In open loop, the ECM does not use the air/fuel ratio sensor signals. Instead, it calculates the fuel injector pulse width based on MAF and engine temperature. The system will stay in open loop until all of these conditions are met:
  - ten seconds have elapsed since start up.
  - throttle position is less than 80 %.
- CLOSED LOOP - When the ECM receives valid air/fuel ratio signals and the throttle is open less than 80 %, the system will be in closed loop.
- FUEL CUT OFF MODE - The ECM will turn off the fuel injectors if any of the following are met:
  - vehicle speed reaches 110 mph.
  - engine speed exceeds 6000 rpm while driving.
  - engine speed exceeds 3000 rpm in PARK/NEUTRAL.
  - vehicle is decelerating with engine speed greater than 1500 rpm, engine temperature is greater than 120° F (49° C), and the throttle is closed (APP less than 10 %).

### **ABSOLUTE LOAD**

- The ECM uses the MAF sensor input and stored engine displacement information versus engine speed to calculate the air charge moving through the engine against a theoretical maximum.
- Values of absolute load correlate with volumetric efficiency at wide open throttle (WOT).
- Displayed as a percentage in scan data.
- Normal absolute load at WOT is 95 %.
- Typical values at normal idle are approximately 15 %.



## **VARIABLE VALVE LIFT CONTROL SYSTEM**

- Variable valve lift is used for improved engine efficiency, performance and emissions control.
- The ECM controls variable valve lift in relation to engine rpm. Below 3000 rpm, the VVL system will command motor position to 0 %, base valve lift. Above 3000 rpm, the VVL system will command motor position to 100 % resulting in an additional 4 mm of valve lift.
- Each bank has its own 2-wire motor with position sensors for feedback.
- The VVL position sensors will read 0.50 V at low lift (0 % command) and 4.50 V at high lift (100 % command).
- On each intake camshaft, a DC motor is attached to a rod which operates a fulcrum attached to the rocker arms, effectively changing the rocker arm ratio.
- If there are any faults detected in the VVL system, the VVL will be commanded to the low lift position.
- Anytime the TAC system is in failsafe mode (disabled), the VVL will also be commanded to the lowest lift position.
- The VVL system is not used to control idle speed.

## **VARIABLE VALVE TIMING SYSTEM**

- A single timing chain drives the intake and exhaust cams of both banks of the engine.
- Intake camshaft timing is continuously variable using a hydraulic actuator attached to the front end of each intake camshaft. Engine oil flow to each hydraulic actuator is controlled by a camshaft position actuator control solenoid.
- The exhaust camshaft timing is fixed.
- Camshaft timing is determined by the ECM using the crankshaft position (CKP) sensor and camshaft position sensor (CMP 1 and CMP 2) signals.
- At idle, the intake camshafts are fully retarded and valve overlap is zero degrees.
- At higher speeds and loads, the intake camshafts can be advanced up to 40 crankshaft degrees.
- Each intake camshaft has a separate camshaft position sensor, hydraulic actuator, and control solenoid.
- If little or no oil pressure is received by a hydraulic actuator (typically at engine startup, at idle speed, or during a fault condition), it is designed to mechanically default to the fully retarded position (zero valve overlap), and is held in that position by a spring-loaded locking pin.

# INPUTS - SENSORS

## ACCELERATOR PEDAL POSITION (APP 1 AND APP 2) SENSORS

- A pair of redundant non-adjustable potentiometers that sense accelerator pedal position.
- Located on the accelerator pedal assembly.
- APP 1 sensor output varies from 0.5 volts (pedal released) to 3.5 volts (pedal fully pressed); increasing voltage with increasing pedal position.
- APP 2 sensor output varies from 1.5 volts (pedal released) to 4.5 volts (pedal fully pressed); increasing voltage with increasing pedal position, offset from the APP 1 sensor signal by 1.0 volt.
- ECM interprets an APP of 80 % or greater as a request for wide open throttle.
- A circuit failure of one APP sensor will set a DTC and the ECM will limit the maximum throttle opening to 35 %.
- A circuit failure of both APP sensors, or a correlation error, will set a DTC and disable the TAC.
- When disabled, the spring-loaded throttle plate will return to the default 15 % position (fast idle).

Accelerator Pedal Position (% applied)	APP 1 Sensor Voltage	APP 2 Sensor Voltage
0	0.50	1.50
5	0.65	1.65
10	0.80	1.80
15	0.95	1.95
20	1.10	2.10
25	1.25	2.25
40	1.70	2.70
50	2.00	3.00
60	2.30	3.30
75	2.75	3.75
80	2.90	3.90
100	3.50	4.50

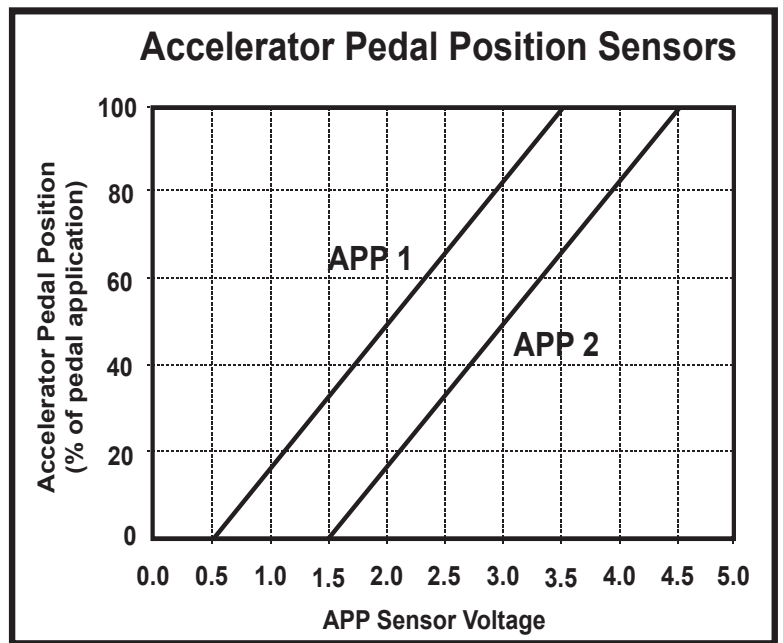

## A/C PRESSURE SENSOR

- Three-wire solid-state sensor for A/C system high-side pressure.
- Sensor output varies from 0.25 volts at 25 psi to 4.50 volts at 450 psi.
- Used as input for A/C compressor clutch control, radiator fan control, and idle speed compensation.
- ECM will disable A/C compressor operation if the pressure is below 40 psi or above 420 psi.
- Located on the A/C high-side vapor line.

A/C High Side Pressure (psi)	Sensor Voltage
25	0.25
50	0.50
100	1.00
150	1.50
200	2.00
250	2.50
300	3.00
350	3.50
400	4.00
450	4.50

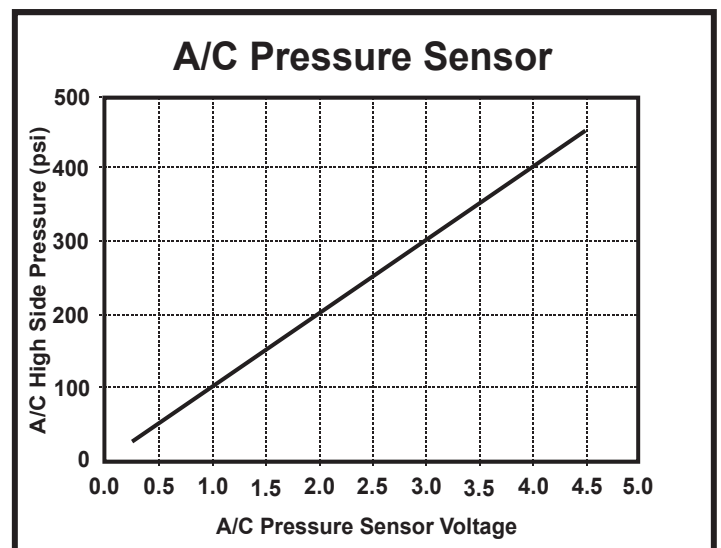

## A/C ON/OFF REQUEST SWITCH

- Normally open (N.O.) switch that closes when A/C compressor operation is requested.
- Status is used by ECM.
- Located in the climate control unit on the instrument panel.

## AIR/FUEL RATIO SENSORS (AFRS 1/1 AND AFRS 2/1)

- Planar-type AFR sensor used by the ECM to measure the air/fuel ratio of the exhaust stream.
- AFRS 1/1 located on the Bank 1 exhaust manifold (cylinders 1, 3, and 5).
- AFRS 2/1 located on the Bank 2 exhaust manifold (cylinders 2, 4, and 6).
- Perfectly balanced air/fuel mixture at 14.7:1 (Lambda 1) = 2.5 volts displayed on the scan tool.
- Lean air/fuel mixture at 20:1 (Lambda 1.36) = 4.3 volts displayed on the scan tool.
- Rich air/fuel mixture at 11:1 (Lambda 0.75) = 1.3 volts displayed on the scan tool.
- ECM monitors polarity and quantity of current to the sensor to determine air/fuel ratio in the exhaust.
- Perfectly balanced air/fuel mixture at 14.7:1 (Lambda 1) = no sensor current produced.
- Rich air/fuel mixture = the sensor produces a negative current between zero and -2000 microamps.
- Lean air/fuel mixture = the sensor produces a positive current between zero and +3000 microamps.
- Battery voltage is continuously supplied to the air/fuel ratio sensor heaters when ignition switch is ON.
- The ECM supplies a pulse width modulated ground to the heaters to control the temperature of the sensor. The duty cycle displayed on the scan tool represents the percent of heater current on time.
- The ECM monitors the AFR heater current.
- The normal AFRS heater resistance is 2-6  $\Omega$  at 68° F (20° C).

Air/Fuel Ratio	Lambda	Scan Tool Voltage	Current (microamps)
20:1	1.36	4.3	+3000
19:1	1.30	4.0	+2440
18:1	1.23	3.7	+1890
17:1	1.16	3.3	+1330
16:1	1.09	3.0	+780
15:1	1.02	2.7	+220
14.7:1	1.00	2.5	0
14:1	0.96	2.3	-330
13:1	0.89	2.0	-890
12:1	0.82	1.7	-1440
11:1	0.75	1.3	-2000

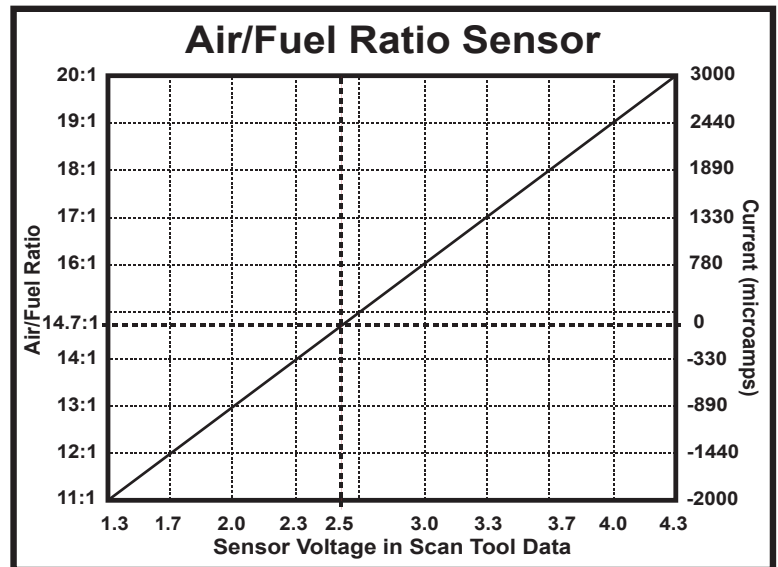

## BRAKE PEDAL POSITION (BPP) SWITCH

- Normally open (N.O.) switch that closes when the brake pedal is pressed/applied.
- Status is used by TCM.
- Located on the brake pedal.

## CAMSHAFT POSITION SENSORS (CMP 1 AND CMP 2)

- A pair of three-wire solid state Hall-effect sensors that generate a signal once per intake camshaft revolution.
- Located at the rear of each valve cover, the sensors are triggered by an interrupter on the intake camshafts.
- The leading edge of the bank 1 CMP signal occurs on the cylinder 1 compression stroke, and the leading edge of the bank 2 CMP signal occurs on the cylinder 4 compression stroke.
- When the intake camshafts are fully retarded (zero valve overlap), the CMP signals switch from 0 to +5 volts at top dead center compression stroke of cylinders 1 and 4 respectively. When the intake camshafts are fully advanced (maximum valve overlap), the signals switch at 40 crankshaft degrees before top dead center. These signals allow the ECM to determine fuel injector and ignition coil sequence, as well as the actual intake valve timing.
- Loss of one CMP signal will set a DTC, and valve timing defaults to the fully retarded position (zero valve overlap). If neither CMP signal is detected during cranking, the ECM stores a DTC and disables the fuel injectors, resulting in a no-start condition.
- The sensors are not adjustable.
- The diagram at the bottom of this page shows the CKP and CMP sensor signal waveforms with the camshafts at the default (fully retarded) position.

## CRANKSHAFT POSITION (CKP) SENSOR

- A magnetic-type sensor that generates 35 pulses for each crankshaft revolution.
- Located on the front engine cover.
- Triggered by a reluctor wheel mounted on the crankshaft, behind the balancer pulley.
- Each tooth is ten crankshaft degrees apart, with one space for a “missing tooth” located at 60 degrees before top dead center of cylinder number 1.
- The diagram at the bottom of this page shows the CKP sensor signal waveform.

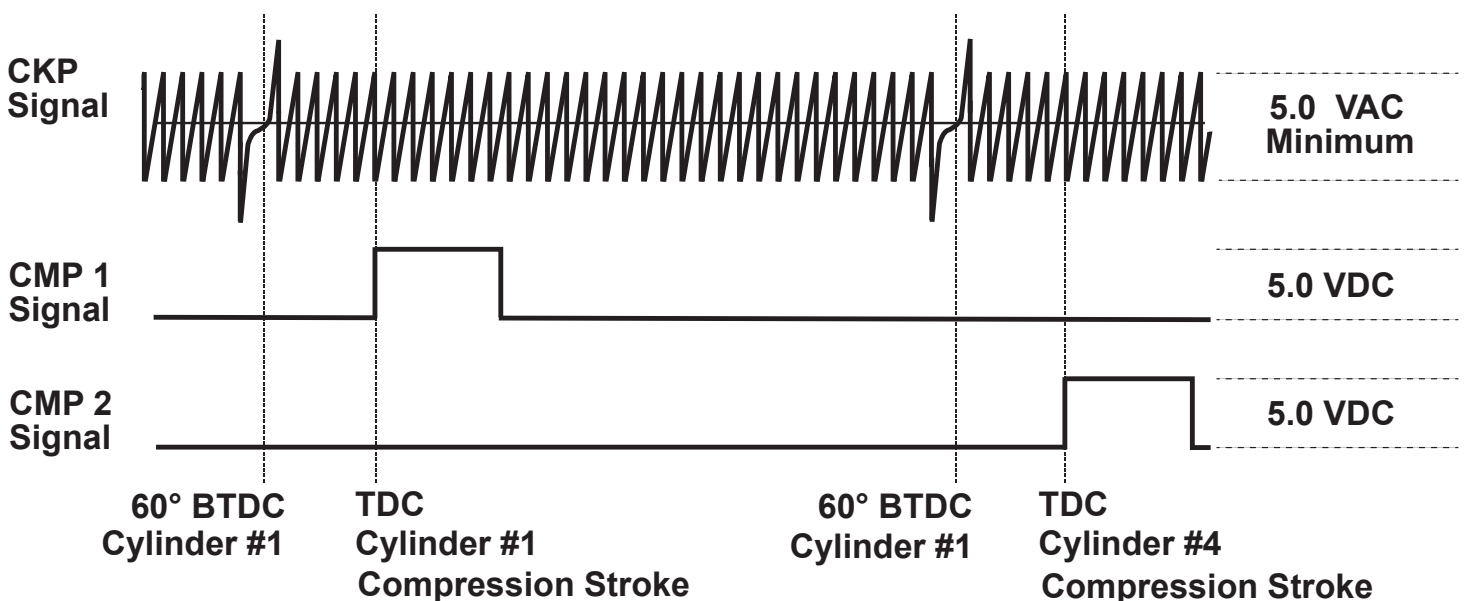

**CMP signals shown at the default (fully retarded) position**

## EGR VALVE POSITION SENSOR

- A three-wire non-adjustable potentiometer that senses the position of the EGR valve pintle.
- Sensor output varies from 0.50 volts (valve fully closed) to 4.50 volts (valve fully open).
- Located on top of the EGR valve.

EGR Valve (% open)	Sensor Voltage
0	0.50
25	1.50
50	2.50
75	3.50
100	4.50

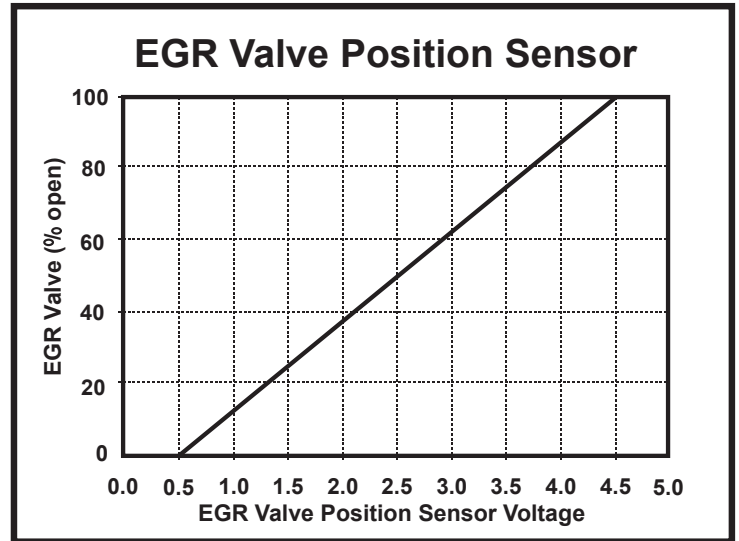

## FUEL LEVEL SENSOR

- A potentiometer that is used to determine the fuel level.
- Sensor output varies from 0.5 volts at 0 % (empty tank) to 4.5 volts at 100 % (full tank).
- Fuel tank at 1/4 full = 1.5 volts.
- Fuel tank at 3/4 full = 3.5 volts.
- Used by the ECM when testing the evaporative emission (EVAP) system.
- Located in the fuel tank.

Fuel Level (% full)	Sensor Voltage
0	0.50
25	1.50
50	2.50
75	3.50
100	4.50

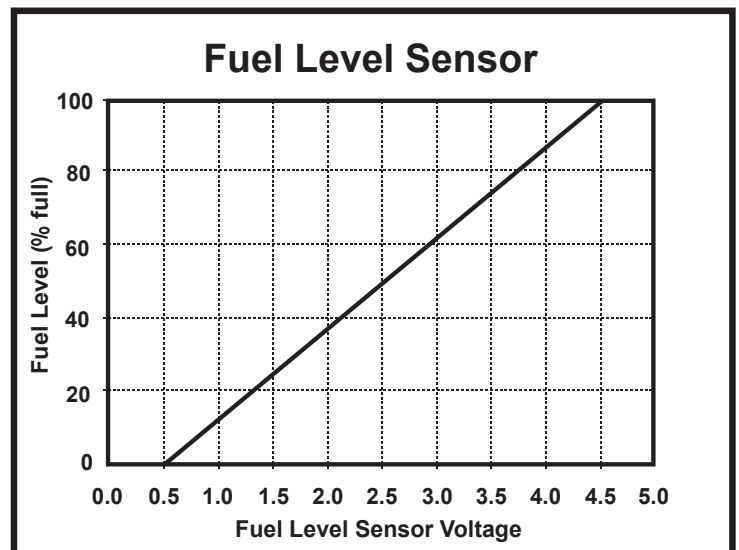

## FUEL PRESSURE (FP) SENSOR

- A five-wire, combined, solid-state sensor used to monitor system pressure.
- Located on the fuel rail. (Also see: Temperature Sensors > Fuel Temperature (FT) Sensor)
- Sensor output varies from 0.50 volts at 0 psi to 4.50 volts at 90 psi. At 60 psi, the pressure sensor reading is 3.2 volts.
- Measurement is referenced to atmosphere and will match mechanical gauge pressure.
- Used by the ECM to measure fuel system pressure and as an input to determine command signal output to the fuel pump control module (FPCM).

Fuel Pressure (psi)	Sensor Voltage
0	0.50
10	0.80
20	1.40
30	1.75
40	2.25
50	2.75
60	3.20
70	3.65
80	4.10
90	4.50

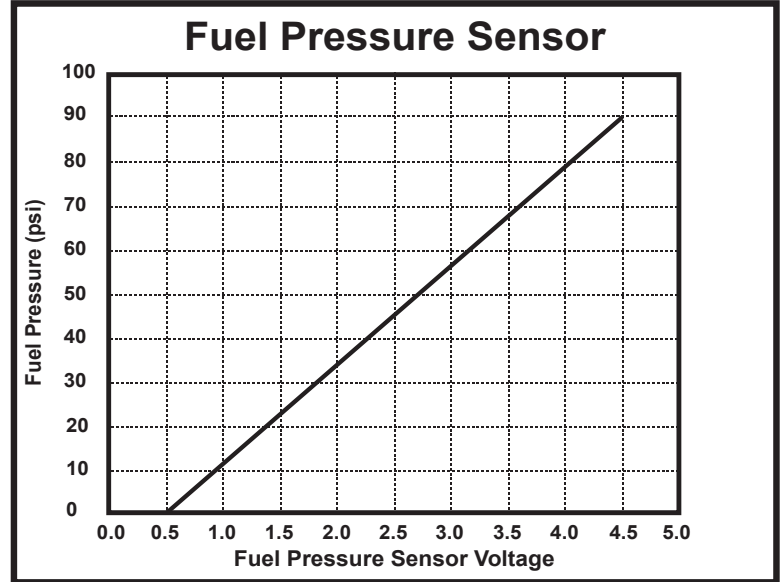

## FUEL TANK (EVAP) PRESSURE SENSOR

- Senses vapor pressure or vacuum in the EVAP system compared to atmospheric pressure.
- Sensor output varies from 0.5 volts at -0.500 psi (-14 in. H<sub>2</sub>O) when under vacuum, to 4.5 volts at 0.500 psi (14 in. H<sub>2</sub>O) when pressurized. With no pressure or vacuum in the fuel tank (fuel cap removed), the sensor output is 2.5 volts.
- Used by the ECM for OBD evaporative emission system diagnostics only.
- Located on top of the fuel tank.

Fuel Tank (EVAP) (in.H <sub>2</sub> O)	Pressure (psi)	Sensor Voltage
-14.0	-0.500	0.50
-10.5	-0.375	1.00
-7.0	-0.250	1.50
-3.5	-0.125	2.00
0.0	0.000	2.50
3.5	0.125	3.00
7.0	0.250	3.50
10.5	0.375	4.00
14.0	0.500	4.50

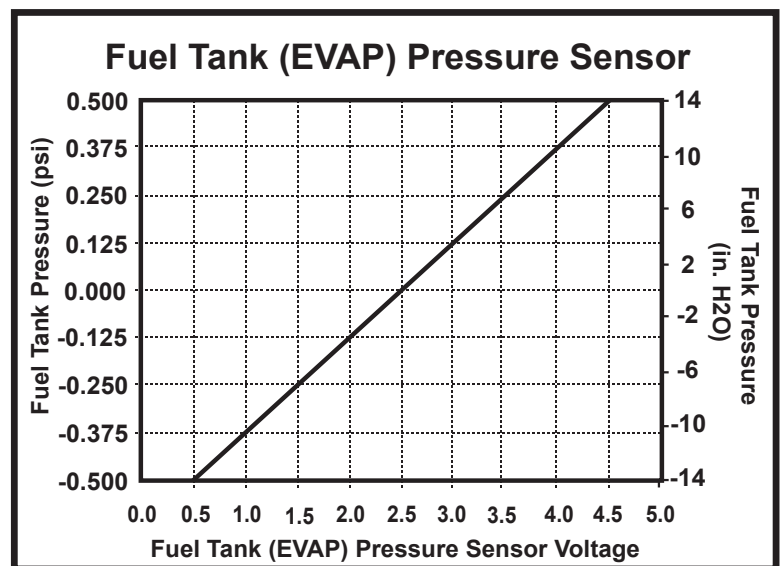

## KNOCK SENSORS

- Two-wire piezoelectric sensors that generate an AC voltage spike when engine vibrations within a specified frequency range are present.
- Located on each bank of the engine block.
- The signal is used by the ECM to retard ignition timing when knock is detected.
- The sensor signal circuit normally measures 2.5 volts DC with the sensor connected.

## HEATED OXYGEN SENSOR (HO2S 1/2 and HO2S 2/2)

- Electrically heated zirconia sensors.
- Mounted in the exhaust pipe (downstream) after the front catalytic converters on each bank.
- Used for OBD monitoring of catalytic converter efficiency.
- Sensor output varies from 0.0 to 1.0 volt.
- No bias voltage is applied to the sensor signal circuits by the ECM.
- With the key ON and engine OFF, the sensor reading is zero volts.
- Battery voltage is continuously supplied to the oxygen sensor heaters when the ignition switch is ON.
- Once the engine is started, the ECM will provide the ground for the downstream oxygen sensor heaters after two minutes of continuous engine operation.
- Normal oxygen sensor heater resistance is 8-12  $\Omega$  at 68° F (20° C).

## IGNITION SWITCH

- Provides ignition key position input to the ECM.
- With the key in the RUN position and engine speed greater than 400 rpm, if an ignition switch fault is detected the engine will continue to run.

	IGN SW Pin a / ECM Pin 221	IGN SW Pin b / ECM Pin 222	IGN SW Pin c / ECM Pin 223	IGN SW Pin d / ECM Pin 224
<b>OFF</b>	0.0 V	B+	B+	B+
<b>ACC</b>	B+	0.0 V	B+	B+
<b>RUN</b>	B+	B+	0.0 V	B+
<b>START</b>	B+	B+	B+	0.0 V

## MANIFOLD ABSOLUTE PRESSURE (MAP) SENSOR

- Senses intake manifold absolute pressure.
- Located on the intake manifold.
- Used by the ECM for OBD diagnostics and barometric pressure (BARO) calculation.
- ECM determines atmospheric altitude (BARO) during key ON/engine OFF.
- The normal BARO for the vehicle is sea level; 30 in. Hg (101 kPa).
- MAP sensor output varies between 4.5 volts (0 in. Hg vacuum / 101 kPa pressure) to 0.5 volts (24 in. Hg vacuum / 20.1 kPa pressure).
- Sensor output is 4.50 volts (0 in. Hg vacuum / 101 kPa pressure) at key ON/engine OFF at sea level.
- Sensor output is 1.17 volts at sea level with no load idle at 20 in. Hg vacuum (33.5 kPa pressure).
- ECM uses MAP input at wide open throttle (WOT) engine operation to update BARO measurement.

Vacuum at sea level (in. Hg. Gauge)	Manifold Absolute Pressure (kPa)	Sensor Voltage
0	101.3	4.50
3	91.2	4.00
6	81.0	3.50
9	70.8	3.00
12	60.7	2.50
15	50.5	2.00
18	40.4	1.50
21	30.2	1.00
24	20.1	0.50

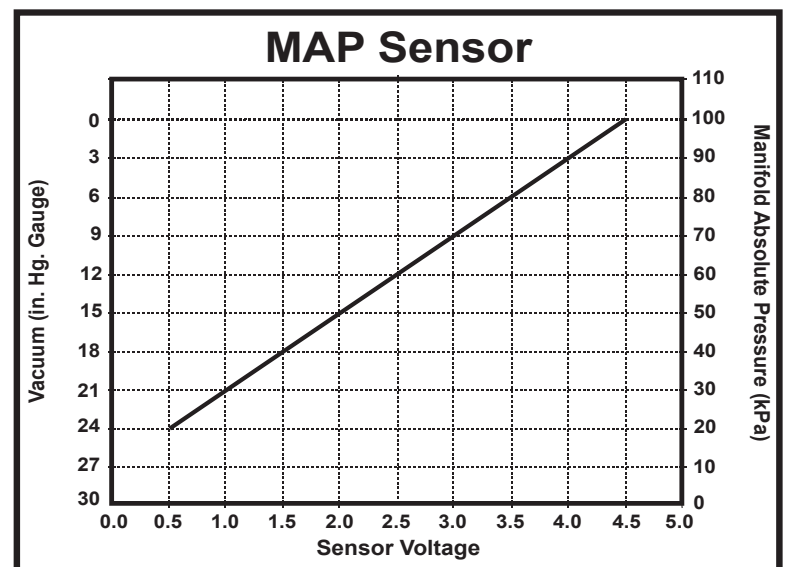



## MASS AIRFLOW (MAF) SENSOR

- A hot-wire design that senses airflow into the intake manifold.
- Located on the air cleaner housing.
- Sensor output varies from 0.2 volts (0 gm/sec) at key ON/engine OFF, to 4.8 volts (175 gm/sec) at maximum airflow.
- At sea level, no-load idle (850 rpm), the sensor reading is 0.85 volts (3.0 gm/sec).

Mass Airflow (gm/sec)	Sensor Voltage
0	0.20
2	0.70
4	1.00
8	1.50
15	2.00
30	2.50
50	3.00
80	3.50
110	4.00
150	4.50
175	4.80

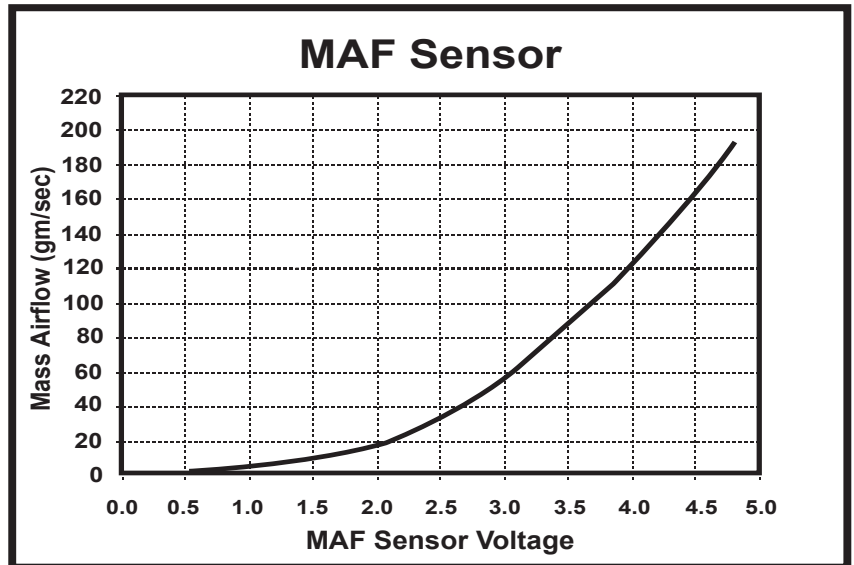

## THROTTLE POSITION (TP 1 AND TP 2) SENSORS

- A pair of redundant non-adjustable potentiometers that sense throttle position.
- Located on the throttle body assembly.
- The TP 1 sensor output varies from 4.5 volts at closed throttle to 0.5 volts at maximum throttle opening (decreasing voltage with increasing throttle position).
- The TP 2 sensor signal varies from 0.5 volts at closed throttle to 4.5 volts at maximum throttle opening (increasing voltage with increasing throttle position).
- A circuit failure of one TP sensor will set a DTC and the ECM will limit the maximum throttle opening to 35 %.
- Circuit failure of both TP sensors, or a correlation error, will set a DTC, and will disable TAC.
- When disabled, the spring-loaded throttle plate returns to the default 15 % position (fast idle).

Throttle Position (% open)	TP 1 Sensor Voltage	TP 2 Sensor Voltage
0	4.50	0.50
5	4.30	0.70
10	4.10	0.90
15	3.90	1.10
20	3.70	1.30
25	3.50	1.50
40	2.90	2.10
50	2.50	2.50
60	2.10	2.90
75	1.50	3.50
80	1.30	3.70
100	0.50	4.50

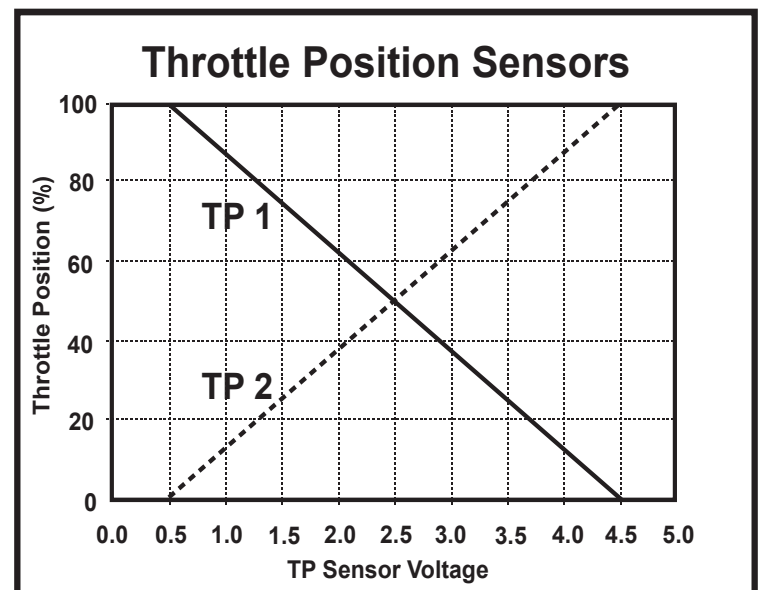

# TEMPERATURE SENSORS

## ENGINE COOLANT TEMPERATURE (ECT) SENSOR

- A negative temperature coefficient (NTC) thermistor that senses engine coolant temperature.
- Located in the engine block water jacket.
- Measures temperatures from -40° F to 248° F (-40° C to 120° C).
- At 212° F (100° C), the sensor reading is 0.46 volts.

## FUEL TEMPERATURE (FT) SENSOR

- A five-wire, combined, solid-state sensor used to monitor fuel system temperature. A negative temperature coefficient (NTC) thermistor that senses fuel rail temperature.
- Located on the fuel rail. (Also see Fuel Pressure (FP) Sensor).
- Measures temperatures from -40° F to 248° F (-40° C to 120° C).
- At 86° F (30° C), the temperature sensor reading is 2.6 volts.
- The signal is used by the ECM to measure fuel system temperature and as an input to determine command signal output to the fuel pump control module (FPCM).

## INTAKE AIR TEMPERATURE (IAT) SENSOR

- A negative temperature coefficient (NTC) thermistor that senses air temperature.
- Located in the air cleaner housing.
- Measures temperatures from -40° F to 248° F (-40° C to 120° C).
- At 86° F (30° C), the sensor reading is 2.6 volts.

## TRANSMISSION FLUID TEMPERATURE (TFT) SENSOR

- A negative temperature coefficient (NTC) thermistor that senses transmission fluid temperature.
- Located in the transaxle oil pan.
- Measures temperatures from -40° F to 248° F (-40° C to 120° C).
- At 212° F (100° C), the sensor reading is 0.46 volts.
- This signal is used by the TCM to delay shifting when the fluid is cold, and control torque converter clutch operation when the fluid is hot.

Temperature ° F	Temperature ° C	Sensor Voltage
248	120	0.25
212	100	0.46
176	80	0.84
150	66	1.34
140	60	1.55
104	40	2.27
86	30	2.60
68	20	2.93
32	0	3.59
-4	-20	4.24
-40	-40	4.90

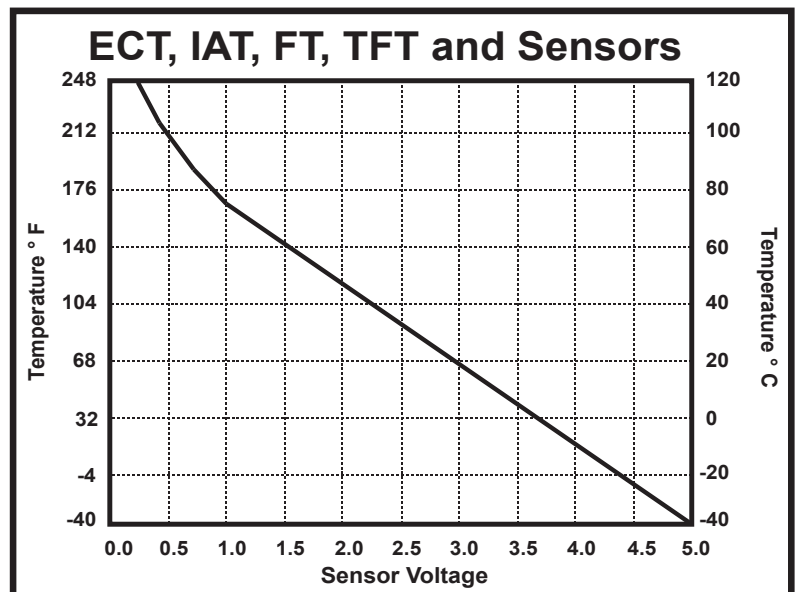

## **TRANSMISSION RANGE (TR) SWITCH**

- A five-position switch that indicates the position of the transaxle manual select lever: PARK, REVERSE, NEUTRAL, DRIVE (D), or LOW (L).
- Located on the transaxle housing.
- Used by the TCM to control line pressure, upshifting, and downshifting.

## **TRANSMISSION TURBINE SHAFT SPEED (TSS) SENSOR**

- A magnetic-type sensor that senses rotation of the torque converter turbine shaft (input/mainshaft).
- Located on the transaxle housing.
- Generates a signal that increases in frequency as transmission input speed increases.
- Used by the TCM to control torque converter clutch operation and sense transmission slippage.

## **VARIABLE VALVE LIFT SYSTEM SENSORS**

- Two, three-wire, non-adjustable potentiometers that sense the variable valve lift motor shaft position for each variable valve lift motor.
- Located in the variable valve lift motor assemblies.
- Sensor output will read 0.50 V at low lift (0 % command) and 4.50 V at high lift (100 % command).
- Normal ECM command of the motors at idle is base lift. At wide open throttle (WOT), maximum load, the ECM commands maximum additional lift.

## **VEHICLE SPEED SENSOR (VSS)**

- A magnetic-type sensor that senses rotation of the final drive.
- Located on the transaxle housing.
- Generates a signal that increases in frequency as vehicle speed increases.
- The TCM uses the VSS signal to control upshifts, downshifts, and the torque converter clutch.
- The TCM communicates the VSS signal over the data communications bus to the ECM to control high speed fuel cutoff, and to the Instrument Cluster for speedometer operation.
- The signal is displayed on the scan tool in miles per hour and kilometers per hour.

# OUTPUTS - ACTUATORS

## CAMSHAFT POSITION ACTUATOR CONTROL SOLENOIDS

- A pair of duty-cycle controlled solenoid valves that modify the valve timing of the intake camshafts by controlling engine oil flow to the camshaft position actuators.
- As duty cycle increases, oil flows from the solenoid to the actuator advancing the camshaft position.
- As the duty cycle decreases, the amount of oil flow from the solenoid is reduced allowing the camshaft to move back towards the rest position.
- When the ECM determines that the desired camshaft position has been achieved, the duty cycle is commanded to 50 % to hold the actuator so that the adjusted camshaft position is maintained.
- The solenoid winding resistance specification is  $12 \pm 2 \Omega$ .

## EVAPORATIVE EMISSION (EVAP) CANISTER PURGE SOLENOID

- Duty cycle controlled regulation of EVAP canister purge vapor flow into the intake manifold.
- Enabled when the engine coolant temperature reaches 150° F (66° C).
- A duty cycle of 0 % blocks vapor flow, and a duty cycle of 100 % allows maximum vapor flow.
- The duty cycle is determined by the ECM, based on engine speed and load.
- Also used for OBD testing of the evaporative emission (EVAP) system.
- A service port with a schrader valve is on the hose between the purge solenoid and the canister.
- Winding resistance specification is  $36 \pm 4 \Omega$ .

## EVAPORATIVE EMISSION (EVAP) CANISTER VENT SOLENOID

- When energized, the fresh air supply hose to the canister is blocked.
- Energized only during OBD testing of the evaporative emission (EVAP) system.
- Winding resistance specification is  $36 \pm 4 \Omega$ .

## EXHAUST GAS RECIRCULATION (EGR) VALVE

- A duty cycle controlled solenoid that controls the spring-loaded EGR valve pintle.
- A scan tool value of 0 % indicates an ECM command to fully close the EGR valve.
- A scan tool value of 100 % indicates an ECM command to fully open the EGR valve.
- Enabled when the engine coolant temperature reaches 150° F (66° C) and the throttle is not closed or wide open.
- Winding resistance specification is  $12 \pm 2 \Omega$ .

## FAN CONTROL (FC) RELAY

- When energized, the relay provides battery voltage (B+) to the radiator/condenser cooling fan motor.
- Energized when engine coolant temperature reaches 220° F (104° C); off when coolant temperature drops to 195° F (90° C).
- Energized when the A/C high side pressure reaches 300 psi (2068 kPa); off when the pressure drops to 250 psi (1724 kPa).
- Coil resistance specification is  $36 \pm 4 \Omega$ .

## FUEL INJECTORS

- Electromechanical devices used to deliver fuel to the intake manifold at each cylinder.
- Each individually energized once per camshaft revolution, in time with its cylinder's exhaust stroke.
- Winding resistance specification is  $12 \pm 2 \Omega$ .

## GENERATOR

- The ECM supplies a variable duty-cycle signal to ground the field winding of the generator (alternator).
- The ECM receives battery/charging voltage input at pin 219. This pin is a dedicated generator input.
- Increased duty cycle results in a higher field current and greater generator (alternator) output.

## **IGNITION COILS**

- Coil-on-plug (COP) system with six individual coils connected directly to the spark plugs.
- Timing and dwell are controlled by the ECM.
- Coil primary resistance specification is  $1 \pm 0.5 \Omega$ .
- Coil secondary resistance specification is  $10K \pm 2K \Omega$ .

## **MALFUNCTION INDICATOR LAMP (MIL)**

- Part of the instrument cluster module (ICM).
- Receives commands from the ECM and TCM over the data communications bus.
- If the ICM is unable to communicate with the communications bus network, the MIL will be lit.
- With no faults present, the MIL is lit for 5 seconds after the ignition switch is turned ON (bulb check).
- An emissions-related fault is present if the MIL stays lit after the bulb check.
- When misfiring occurs that could damage a catalytic converter, the MIL flashes on and off.

## **STARTER RELAY**

- When energized, provides battery voltage (B+) to the starter solenoid.
- Energized based upon ignition switch position (START), transmission range switch position (PARK/NEUTRAL), vehicle speed (0 mph), and engine speed (0 rpm).
- Coil resistance specification is  $36 \pm 4 \Omega$ .

## **THROTTLE ACTUATOR CONTROL (TAC) MOTOR**

- A bidirectional pulse-width modulated DC motor that controls the position of the throttle plate.
- Scan tool data value of 0 % = ECM command to fully close throttle plate.
- Scan tool value of 100 % = ECM command to fully open the throttle plate (wide open throttle).
- Any throttle control actuator motor circuit fault sets a DTC and causing the TAC to be disabled, and the spring-loaded throttle plate will return to the default 15 % position (fast idle).
- When disabled, the TAC value on the scan tool will indicate 15 %.
- Maximum throttle actuator control motor current is 6 amps.

## **TRANSMISSION SOLENOIDS**

### **TORQUE CONVERTER CLUTCH (TCC) SOLENOID VALVE**

- This normally low (NL) variable force solenoid controls fluid in the transmission valve body that is routed to the torque converter clutch.
- TCM varies duty cycle to maintain a controlled slip or a full application of the clutch (zero slip).
- Scan tool duty cycle value of 0 % = TCC is released.
- When torque converter clutch application is desired, the pulse width increases.
- Scan tool duty cycle value of 100 % = TCC is fully applied.
- The duty cycle is immediately cut to 0 % (released) if the brake pedal position switch closes.
- Enabled when the engine coolant temperature reaches 150° F (66° C), the brake switch is open, the transmission is in 3rd gear or higher, and the vehicle is at cruise (steady throttle) above 35 mph.
- Winding resistance specification is  $6 \pm 1 \Omega$ .

### **TRANSMISSION ELECTRONIC PRESSURE CONTROL (EPC) SOLENOID**

- This normally high (NH) variable force solenoid controls fluid in the transmission valve body that is routed to the pressure regulator valve.
- TCM varies duty cycle to modify the line pressure of the transmission for best shift quality.
- Scan tool duty cycle value of 10 % = maximum line pressure command.
- Scan tool duty cycle value of 90 % = minimum line pressure is commanded.
- Winding resistance specification is  $6 \pm 1 \Omega$ .

## TRANSMISSION SHIFT SOLENOIDS (SS A, SS B, SS C, SS D, and SS E)

- Control fluid flow to the clutches.
- Located in the transmission valve body.
- SS A and SS D are normally low (NL) variable force solenoids.
- SS B and SS C are normally high (NH) variable force solenoids.
- SS E is an OFF/ON solenoid that is normally closed (NC).
- By modifying the duty cycle of the variable force solenoids and changing the state of the ON/OFF solenoid, the TCM can control the pressure to the clutches to enable a gear change.
- Winding resistance specification is  $6 \pm 1 \Omega$ , except for SS E which is  $22 \pm 2 \Omega$ .

Gear Selector Position	PCM Gear Command	4-5-6 Clutch	3-5-R Clutch	2-6 Clutch	L-R Clutch	1-2-3-4 Clutch	Low/One-Way Clutch	SS A (VFS) 1-2-3-4 Clutch NL	SS B (VFS) L-R/ 4-5-6 NH	SS C (VFS) 3-5-R NH	SS D (VFS) 2-6 NL	SS E (OFF/ON) NC	Gear Ratio
P	P				Applied			OFF	OFF	ON	OFF	ON	
R	R		Applied		Applied			OFF	OFF	OFF	OFF	ON	2.88:1
N	N				Applied			OFF	OFF	ON	OFF	ON	
D	1				Applied	Applied	Applied	ON	OFF	ON	OFF	ON	4.48:1
	2			Applied		Applied	OR	ON	ON	ON	ON	OFF	2.87:1
	3		Applied			Applied	OR	ON	ON	OFF	OFF	OFF	1.84:1
	4	Applied				Applied	OR	ON	OFF	ON	OFF	OFF	1.41:1
	5	Applied	Applied				OR	OFF	OFF	OFF	OFF	OFF	1:1
	6	Applied		Applied			OR	OFF	OFF	ON	ON	OFF	0.74:1
L	L				Applied	Applied		ON	OFF	ON	OFF	ON	4.48:1

VFS = Variable Force Solenoid  
NC = Normally Closed

NL = Normally Low  
NH = Normally High

OR = Over Running

**Normally Low (NL):** When this solenoid type is OFF (not energized), fluid pressure is low, fluid is exhausted from the circuit, and the clutch is not applied. When the solenoid is ON (energized), the TCM increases the fluid pressure by varying the solenoid duty cycle and the clutch is applied.

**Normally High (NH):** When this solenoid type is OFF (not energized), fluid pressure is high in the fluid circuit and the clutch is applied. When the solenoid is ON (energized), the TCM reduces the fluid pressure by varying the solenoid duty cycle and the clutch is released.

**Normally Closed (NC):** This solenoid type is either ON or OFF and controls a three-port hydraulic circuit to aid in shift strategy. Regulated line pressure is switched between two hydraulic ports, a default passage, and a primary passage. When this solenoid type is OFF (not energized), oil is blocked from the primary oil passage and fed to a default passage. When the solenoid is ON (energized), the TCM redirects the fluid pressure to the primary oil passage.

## **VARIABLE VALVE LIFT MOTORS**

- A bidirectional DC motor that controls the position of the variable valve lift mechanism.
- DC motor is attached to a rod which operates a fulcrum attached to the rocker arms.
- Changes in rocker arm ratio result in additional lift above the base lift provided by the camshaft lobes.
- Scan tool value below 3000 rpm = 0.5 V (0 %).
- Scan tool value above 3000 rpm = 4.5 V (100 %).



# OBD SYSTEM OPERATION

## DATA COMMUNICATIONS

### POWERTRAIN COMMUNICATIONS NETWORK

- High-speed, serial data bus.
- Two-wire twisted pair communications network.
- Allows peer-to-peer communications between the ECM, TCM, instrument cluster (including the MIL), immobilizer control module, and a scan tool connected to the data link connector (DLC).
- Data-High circuit switches between 2.5 (rest state) and 3.5 volts (active state).
- Data-Low circuit switches between 2.5 (rest state) and 1.5 volts (active state).
- Two, 120-ohm terminating resistors: one inside the instrument cluster and another inside the ECM.
- Any of the following conditions will cause serial data bus communications to fail and result in the storage of network DTCs:
  - either data line shorted to voltage.
  - either data line shorted to ground.
  - one data line shorted to the other data line.
  - an open in either data line to a module.
- Data bus remains operational when one of the two modules containing a terminating resistor is not connected to the network.
- Data bus will fail when both terminating resistors are not connected to the network.
- Communication failures will not prevent the ECM from providing control of the ignition system.

### FUEL PUMP CONTROL MODULE (FPCM) COMMUNICATIONS NETWORK

- Local Area Network (LAN) bus.
- Two-wire, twisted pair communications network; isolated from the powertrain communications network.
- Allows peer-to-peer communications between the ECM and the FPCM only.
- LAN Data-High circuit switches between 2.5 (rest state) and 3.5 volts (active state).
- LAN Data-Low circuit switches between 2.5 (rest state) and 1.5 volts (active state).
- Any of the following conditions will cause LAN data bus communications to fail:
  - either data line shorted to voltage.
  - either data line shorted to ground.
  - either data line open.
  - one data line shorted to the other data line.

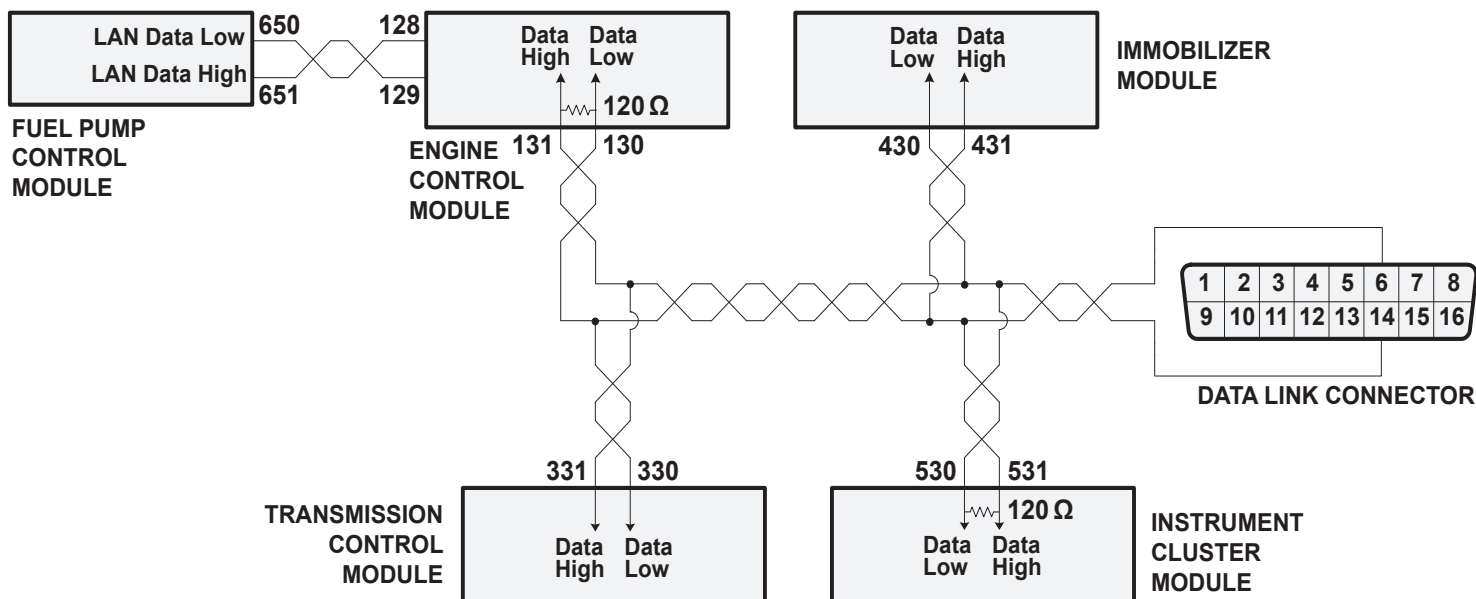



## **SYSTEM MONITORS**

The OBD diagnostic system also actively tests some systems for proper operation while the vehicle is being driven. Fuel control and engine misfire are checked continuously. Air/fuel ratio sensor response, air/fuel ratio sensor heater operation, oxygen sensor response, oxygen sensor heater operation, catalyst efficiency, EGR operation and EVAP integrity are tested once or more per trip. When any of the System Monitors detects a failure that will result in emissions exceeding a predetermined level on two consecutive trips, the ECM will store a diagnostic trouble code (DTC) and illuminate the malfunction indicator lamp (MIL). Freeze frame data captured during the first of the two consecutive failures is also stored.

### **AIR/FUEL RATIO & OXYGEN SENSORS**

- Checks the maximum and minimum signal output and response times for all air/fuel ratio sensors and oxygen sensors.
- If an air/fuel ratio sensor or oxygen sensor signal remains too low, too high, responds too slowly, or does not respond, a DTC is set.

### **AIR/FUEL RATIO & OXYGEN SENSOR HEATERS**

- Checks the current flow through each air/fuel ratio sensor heater and the oxygen sensor heater.
- If the current flow is too high or too low, a DTC is set.
- Battery voltage is continuously supplied to the air/fuel ratio sensor heaters and oxygen sensor heaters whenever the ignition switch is on.
- The heaters are grounded through the ECM.

### **CATALYTIC CONVERTER**

- Compares the data from the heated air/fuel ratio sensors (upstream) to the heated oxygen sensors (downstream) to determine the oxygen storage capability of the catalysts.
- If a catalyst's oxygen storage capacity is sufficiently degraded, the ECM will store the appropriate DTC and illuminate the MIL.
- Will run only after the air/fuel ratio sensor heater, oxygen sensor heater, air fuel ratio sensor and oxygen sensor monitors have run and passed.

### **COMPREHENSIVE COMPONENT**

- Continuous monitor of all engine and transmission sensors and actuators for shorts and opens, as well as values that do not logically fit with other powertrain data (rationality).
- On the first trip where a failure is detected, the ECM or TCM will store a DTC. The ECM will then store a freeze frame of data and illuminate the MIL.

### **EGR SYSTEM**

- Uses the MAP sensor signal to detect changes in intake manifold pressure as the EGR valve is commanded open and closed.
- If the pressure changes too little or too much as compared to the EGR valve position sensor input, a DTC is set.

### **ENGINE MISFIRE**

- Uses the CKP sensor signal to continuously detect engine misfires, both severe and non-severe.
- If the misfire is severe enough to cause catalytic converter damage, the MIL will flash on and off as long as the severe misfire is detected.

## **EVAP SYSTEM**

- Tests for small leaks (0.020 in./0.5 mm) and large leaks (.040 in./1.0 mm).
- Engine off, natural vacuum leak detection is used to test for a small leak (0.020 in./0.5 mm).
  - Enable criteria for the small leak test:
    - the vehicle must have been driven between 15 to 90 minutes.
    - fuel level must be between 1/4 and 3/4 full.
    - ambient air temperature must be between 40° F (4.4° C) and 105° F (40° C).
    - the key is OFF/the engine is OFF.
  - When the key is turned OFF, the vent solenoid is left open for ten minutes to allow the system to stabilize. The ECM then notes the fuel tank pressure (FTP).
  - The ECM then energizes the EVAP vent solenoid for four minutes while monitoring the fuel tank pressure (FTP) sensor for a pressure change.
  - If the system reaches the target value, a change of greater than 1.0 in. H<sub>2</sub>O from the stabilized reading, the test is complete and the system passes (no leak detected).
  - If the system fails to pass the initial small leak test, the ECM will then command the EVAP vent solenoid open for two minutes. The ECM then notes the fuel tank pressure (FTP).
  - The ECM then energizes the EVAP vent solenoid for 20 minutes while monitoring the FTP sensor for change.
  - A change in fuel tank pressure of greater than 1.0 in. H<sub>2</sub>O indicates a pass (no leak detected).
- Vacuum decay is used to test for a large leak (.040 in./1.0 mm).
  - Enable criteria for the large leak test:
    - a cold start with engine temperature below 86° F (30° C).
    - fuel level must be between 1/4 and 3/4 full.
    - ambient air temperature must be between 40° F (4.4° C) and 105° F (40° C).
    - the engine is running.
  - The ECM turns on the EVAP vent solenoid, blocking the fresh air supply to the EVAP canister.
  - The EVAP purge solenoid is turned on to draw a slight vacuum on the entire EVAP system, including the fuel tank.
  - Then the EVAP purge solenoid is turned off to seal the system.
  - The monitor uses the Fuel Tank (EVAP) Pressure Sensor signal to determine if the EVAP system has any leaks.
  - After the testing is completed, the EVAP vent solenoid is turned off to relieve the vacuum.
- A small leak DTC will set if a sufficient change in fuel tank pressure is not achieved during the small leak test.
- A large leak DTC will set if sufficient vacuum is not created, or decays too rapidly, or does not decay quickly at the conclusion of the large leak test.

## **FUEL CONTROL**

- Uses fuel trim and loop status to determine failures in the fuel system.
- Sets a DTC if the system fails to enter Closed Loop mode within 2 minutes of startup.
- Sets a DTC if Long Term Fuel Trim reaches its limit (+30 % or -30 %) indicating a loss of fuel control.

## MONITOR READINESS STATUS

- Indicates whether or not the OBD diagnostic monitor has completed.
- If the monitor has not completed, the status on the scan tool displays “NOT COMPLETE.”
- If the monitor has completed, the status on the scan tool displays “COMPLETE.”
- When DTCs are cleared from memory or the battery is disconnected, all non-continuous monitors will have the readiness status indicators reset to “NOT COMPLETE.”
- The readiness status of the following non-continuous system monitors can be read on the scan tool:
  - Catalytic Converter
  - EGR System
  - EVAP System
  - Oxygen Sensors
  - Oxygen Sensor Heaters

## WARM UP CYCLE

- Used by the ECM and TCM for automatic clearing of DTCs and Freeze Frame data (described below).
- Must have an increase of at least 40° F (an increase of 22° C) and reach a minimum of 160° F (71° C).

## TRIP

- A key-on cycle in which all enable criteria for a diagnostic monitor are met and the monitor is run.
- The trip completes when the ignition switch is turned off.

## DRIVE CYCLE

Most OBD monitors will run at some time during normal operation of the vehicle. However, to satisfy all of the different Trip enable criteria and run all of the OBD diagnostic monitors, the vehicle must be driven under a variety of conditions. The following drive cycle will allow all monitors to run on this vehicle.

- Ensure that the fuel tank is between 1/4 and 3/4 full.
- Engine cold start below 86° F (30° C).
- Engine warm up until coolant temperature is at least 160° F (71° C).
- Accelerate to 40-55 mph at 25 % throttle and maintain speed for 5 minutes.
- Decelerate without using the brake (coast down) to 20 mph or less, and then stop the vehicle. Allow the engine to idle for 10 seconds, turn the key off, and wait 1 minute.
- Restart and accelerate to 40-55 mph at 25 % throttle and maintain speed for 2 minutes.
- Decelerate without using the brake (coast down) to 20 mph or less, and then stop the vehicle. Allow the engine to idle for 10 seconds, turn the key off, and wait 45 minutes.

## FREEZE FRAME DATA

- A snapshot (one frame of data) that is automatically stored in the memory of either the ECM or TCM when an emission-related DTC is first stored (pending).
- If a DTC for fuel control or engine misfire is stored at a later time, the newest data is stored, replacing the earlier data.
- All parameter ID (PID) values listed under “Scan Tool Data” are stored in freeze frame data.
- The ECM and TCM store only one single freeze frame record.

# STORING AND CLEARING DTCS & FREEZE FRAME DATA, TURNING THE MIL ON & OFF

## ONE TRIP MONITORS

- A failure on the first trip of a “one trip” emissions diagnostic monitor causes the ECM or TCM to immediately store a confirmed DTC, capture Freeze Frame data, and turn on the MIL.
- All Comprehensive Component Monitor faults set a confirmed DTC on one trip.

## TWO TRIP MONITORS

- A failure on the first trip of a “two trip” emissions diagnostic monitor causes the ECM to store a pending DTC and Freeze Frame data.
- Normally, if the failure recurs on the next trip during which the monitor runs, regardless of the engine conditions, the ECM will store a confirmed DTC and turn on the MIL.
- For the misfire and fuel control monitors, if the failure recurs on the next trip during which the monitor runs and where conditions are similar to those experienced when the fault first occurred (engine speed within 375 rpm, engine load within 20 %, and same hot/cold warm-up status), the ECM will store a confirmed DTC and turn on the MIL.
- If the second failure does not recur as described above, the pending DTC and Freeze Frame data are cleared from memory.
- All of the System Monitors are two trip monitors.
- Engine misfire which is severe enough to damage the catalytic converter is a two trip monitor. The MIL will always flash on and off when the severe misfire is occurring.

## AUTOMATIC CLEARING

- When the vehicle completes three consecutive good/passing trips (three consecutive trips in which the monitor that set the DTC is run and passes), the MIL will be turned off, but the confirmed DTC and Freeze Frame will remain stored in ECM/TCM memory.
- For misfire and fuel control monitor faults, the three consecutive good/passing trips must take place under similar engine conditions (engine speed, load, and warm up condition) as the initial fault for the MIL to be turned off.
- If the vehicle completes 40 Warm Up cycles without the same fault recurring, the DTC and Freeze Frame are automatically cleared from the ECM/TCM memory.

## MANUAL CLEARING

- Any stored DTCs and Freeze Frame data can be erased using the scan tool, and the MIL (if lit) will be turned off.
- Although not the recommended method, DTCs and Freeze Frame data will also be cleared if the B+ power supply for the ECM/TCM is lost, or the battery is disconnected.

## SCAN TOOL

- Can be used to communicate with the ECM, TCM, Immobilizer, and Instrument Cluster modules.
- Module reprogramming and initialization can be performed using the scan tool.
- The ECM, TCM, and instrument cluster are equipped with software that allows requests to be made through the OBD scan tool for output control of components and functional testing of systems.

Note: All testing is performed at sea level unless otherwise indicated.

## PIN / Component Cross Reference

PIN#	Abbreviation	Diagram	PIN#	Abbreviation	Diagram	PIN#	Abbreviation	Diagram
1	+5 V	1 of 4	152	AFRS 1/1 Heater	2 of 4	337	VSS +	4 of 4
2	Keep Alive Memory	1 of 4	153	AFRS 2/1 +	2 of 4	338	VSS -	4 of 4
3	B+	1 of 4	154	AFRS 2/1 -	2 of 4	340	TSS +	4 of 4
9	A/C Clutch	1 of 4	155	AFRS 2/1 Heater	2 of 4	341	TSS -	4 of 4
10	Fan Control	1 of 4	160	HO2S 1/2 +	2 of 4	343	P	4 of 4
14	Coil 1	1 of 4	161	HO2S 1/2 -	2 of 4	344	R	4 of 4
15	Coil 3	1 of 4	162	HO2S 1/2 Heater	2 of 4	345	N	4 of 4
16	Coil 5	1 of 4	163	HO2S 2/2 +	2 of 4	346	D	4 of 4
17	Coil 2	1 of 4	164	HO2S 2/2 -	2 of 4	347	L	4 of 4
18	Coil 4	1 of 4	165	HO2S 2/2 Heater	2 of 4	348	+5 V	4 of 4
19	Coil 6	1 of 4	171	BPP	2 of 4	350	Sensor Ground	4 of 4
22	TAC	1 of 4	172	A/C Request	2 of 4	360	Ground	4 of 4
23	TAC	1 of 4	181	MAF	2 of 4	402	Ign.	4 of 4
24	TP 1	1 of 4	201	Starter Control	3 of 4	405	Ant. +	4 of 4
25	TP 2	1 of 4	203	CMP 1 Solenoid	3 of 4	406	Ant. -	4 of 4
28	EGR Position	1 of 4	204	CMP 2 Solenoid	3 of 4	430	Data Low	4 of 4
29	MAP	1 of 4	205	VVLB1 A	3 of 4	431	Data High	4 of 4
30	FPS	1 of 4	206	VVLB1 B	3 of 4	460	Ground	4 of 4
31	FTS	1 of 4	207	+5 V	3 of 4	502	Ign.	4 of 4
34	ECT	1 of 4	208	VVLS 1	3 of 4	530	Data Low	4 of 4
35	IAT	1 of 4	209	Sensor Ground	3 of 4	531	Data High	4 of 4
40	A/C Pressure	1 of 4	210	VVLB2 A	3 of 4	560	Ground	4 of 4
41	Fuel Tank Pressure	1 of 4	211	VVLB2 B	3 of 4	605	B+	2 of 4
42	Fuel Level	1 of 4	212	+5 V	3 of 4	610	FP Feed B+	2 of 4
50	Sensor Ground	1 of 4	213	VVLS 2	3 of 4	611	FP Ground	2 of 4
60	Ground	1 of 4	214	Sensor Ground	3 of 4	649	FP Enable	2 of 4
101	Generator Field	2 of 4	219	Battery Sense	3 of 4	650	LAN Data Low	2 of 4
104	EVAP Vent	2 of 4	221	IGN OFF	3 of 4	651	LAN Data High	2 of 4
108	EGR	2 of 4	222	IGN ACC	3 of 4	660	Ground	2 of 4
110	EVAP Purge	2 of 4	223	IGN RUN	3 of 4		<b>Component</b>	<b>Diagram</b>
120	INJ 1	2 of 4	224	IGN START	3 of 4		Connector 1	1
121	INJ 2	2 of 4	240	KS B1	3 of 4		Connector 8	4
122	INJ 3	2 of 4	241	KS B2	3 of 4		Connector 12	4
123	INJ 4	2 of 4	250	CMP 1	3 of 4		Connector 25	4
124	INJ 5	2 of 4	251	CMP 2	3 of 4		Fuse 2	1
125	INJ 6	2 of 4	252	CKP +	3 of 4		Fuse 3	1
127	FP Enable	2 of 4	253	CKP -	3 of 4		Fuse 4	1
128	LAN Data Low	2 of 4	302	Ign.	4 of 4		Fuse 20	2
129	LAN Data High	2 of 4	303	B+	4 of 4		Fuse 22	2
130	Data Low	2 of 4	305	TCC	4 of 4		Fuse 30	3
131	Data High	2 of 4	306	EPC	4 of 4		Fuse 31	3
140	+5 V	2 of 4	307	SS A	4 of 4		Fuse 32	3
141	APP 1	2 of 4	308	SS B	4 of 4		Fuse 33	3
142	Sensor Ground	2 of 4	309	SS C	4 of 4		Fuse 34	3
143	+5 V	2 of 4	310	SS D	4 of 4		Fuse 40	4
144	APP 2	2 of 4	311	SS E	4 of 4		Fuse 41	4
145	Sensor Ground	2 of 4	330	Data Low	4 of 4		Fuse 42	4
150	AFRS 1/1 +	2 of 4	331	Data High	4 of 4		Fuse 43	4
151	AFRS 1/1 -	2 of 4	336	TFT	4 of 4		Fuse 44	4

The information on these two pages are the data values, including minimum-to-maximum ranges, that the OBD II scan tool is capable of displaying for each of the data parameters.

<b>Absolute Load Value</b>	0 to 100 %
<b>A/C Clutch</b>	ON / OFF
<b>A/C Pressure</b>	25 to 450 psi / 0.0 to 5.0 V
<b>A/C Request</b>	ON / OFF
<b>AFRS 1/1</b>	-1.00 to 5.00 V
<b>AFRS 2/1</b>	-1.00 to 5.00 V
<b>AFRS 1/1 Current</b>	-9999 to +9999 microamps
<b>AFRS 2/1 Current</b>	-9999 to +9999 microamps
<b>AFRS 1/1 Heater</b>	0 to 100 %
<b>AFRS 2/1 Heater</b>	0 to 100 %
<b>Air/Fuel Lambda Bank 1</b>	0.00 to 2.00
<b>Air/Fuel Lambda Bank 2</b>	0.00 to 2.00
<b>APP 1</b>	0 to 100 % / 0.0 to 5.0 V
<b>APP 2</b>	0 to 100 % / 0.0 to 5.0 V
<b>BARO</b>	101 to 67 kPa pressure / 30 to 20 in.Hg. pressure
<b>Battery Voltage</b>	0 to 18 V
<b>Brake Pedal Position Switch</b>	ON / OFF
<b>Cam 1 Desired Advance</b>	0 to 99°
<b>Cam 2 Desired Advance</b>	0 to 99°
<b>Cam 1 Solenoid Control</b>	0 to 100 %
<b>Cam 2 Solenoid Control</b>	0 to 100 %
<b>CMP 1</b>	0° to 99°
<b>CMP 2</b>	0° to 99°
<b>Distance traveled since DTCs cleared</b>	##### miles/km
<b>Distance traveled with MIL on</b>	##### miles/km
<b>DTCs (confirmed)</b>	P#####, U#####, etc.
<b>DTCs (pending)</b>	P#####, U#####, etc.
<b>ECT</b>	248 to -40° F / 120 to -40° C / 0.0 to 5.0 V
<b>EGR Position Sensor</b>	0 to 100 % / 0.0 to 5.0 V
<b>EGR Valve Opening Desired</b>	0 to 100 %
<b>Electronic Pressure Control (EPC)</b>	0 to 100 %
<b>Engine RPM</b>	0 to 9999 rpm
<b>Evap Purge Solenoid</b>	0 to 100 %
<b>Evap Vent Solenoid</b>	ON / OFF
<b>Fan Control</b>	ON / OFF
<b>Fuel Enable</b>	YES / NO
<b>Fuel Pressure</b>	0.00 to 5.00 V / 0 to 90 psi
<b>Fuel Pump Command (ECM)</b>	OFF / LOW / HIGH
<b>Fuel Pump Feedback (FPCM)</b>	0 to 100 %
<b>Fuel Tank (EVAP) Pressure</b>	-14.0 to +14.0 in.H2O / -0.5 psi to 0.5 psi / 0.0 to 5.0 V
<b>Fuel Tank Level</b>	0 to 100 % / 0.0 to 5.0 V
<b>Fuel Temperature</b>	248 to -40° F / 120 to -40° C / 0.0 to 5.0 V
<b>Generator Field</b>	0 to 100 %



The information on these two pages are the data values, including minimum-to-maximum ranges, that the OBD II scan tool is capable of displaying for each of the data parameters.

HO2S 1/2	-1.00 to 2.00 V
HO2S 2/2	-1.00 to 2.00 V
HO2S 1/2 Heater	ON / OFF
HO2S 2/2 Heater	ON / OFF
IAT	248 to -40° F / 120 to -40° C / 0.0 to 5.0 V
Ignition Switch	OFF / ACC / RUN / START
Ignition Timing Advance	-99° to 99° BTDC
Injector Pulse Width Bank 1	0 TO 99 ms
Injector Pulse Width Bank 2	0 to 99 ms
Knock Sensor B1 (knock detected)	YES / NO
Knock Sensor B2 (knock detected)	YES / NO
Long Term Fuel Trim Bank 1	-99 % to +99 %
Long Term Fuel Trim Bank 2	-99 % to +99 %
Loop Status	OPEN / CLOSED
MAF	0 to 175 gm/sec / 0.0 to 5.0 V
MAP	20 to 101 kPa pressure / 24 to 0 in.Hg. vacuum / 0.0 to 5.0 V
MIL	ON / OFF / FLASHING
Monitor Status for this trip	DISABLED / NOT COMPLETE / COMPLETE
Number warm-up cycles since DTCs cleared	###
Shift Solenoid A	0 to 100 %
Shift Solenoid B	0 to 100 %
Shift Solenoid C	0 to 100 %
Shift Solenoid D	0 to 100 %
Shift Solenoid E	ON / OFF
Short Term Fuel Trim Bank 1	-99 % to +99 %
Short Term Fuel Trim Bank 2	-99 % to +99 %
Software Calibration ID Number	(CAL ID)
Software Verification Number	(CVN)
Starter Relay	ON / OFF
TCC	0 to 100 %
TFT	248 to -40° F / 120 to -40° C / 0.0 to 5.0 V
Throttle Actuator Control	0 to 100 %
Time elapsed since engine start	hh:mm:ss
TP 1	0 to 100 % / 0.0 to 5.0 V
TP 2	0 to 100 % / 0.0 to 5.0 V
TR	P, N, R, D, L
TSS	0 to 9999 rpm
Valid Ignition Key	YES / NO
Variable Valve Lift Bank 1 Commanded	ON / OFF
Variable Valve Lift Bank 2 Commanded	ON / OFF
Variable Valve Lift Position Bank 1	0 to 100 % / 0.0 to 5.0 V
Variable Valve Lift Position Bank 2	0 to 100 % / 0.0 to 5.0 V
Vehicle Identification Number	(VIN)
VSS	0 to 199 mph



# Electrical Diagram 1 of 4

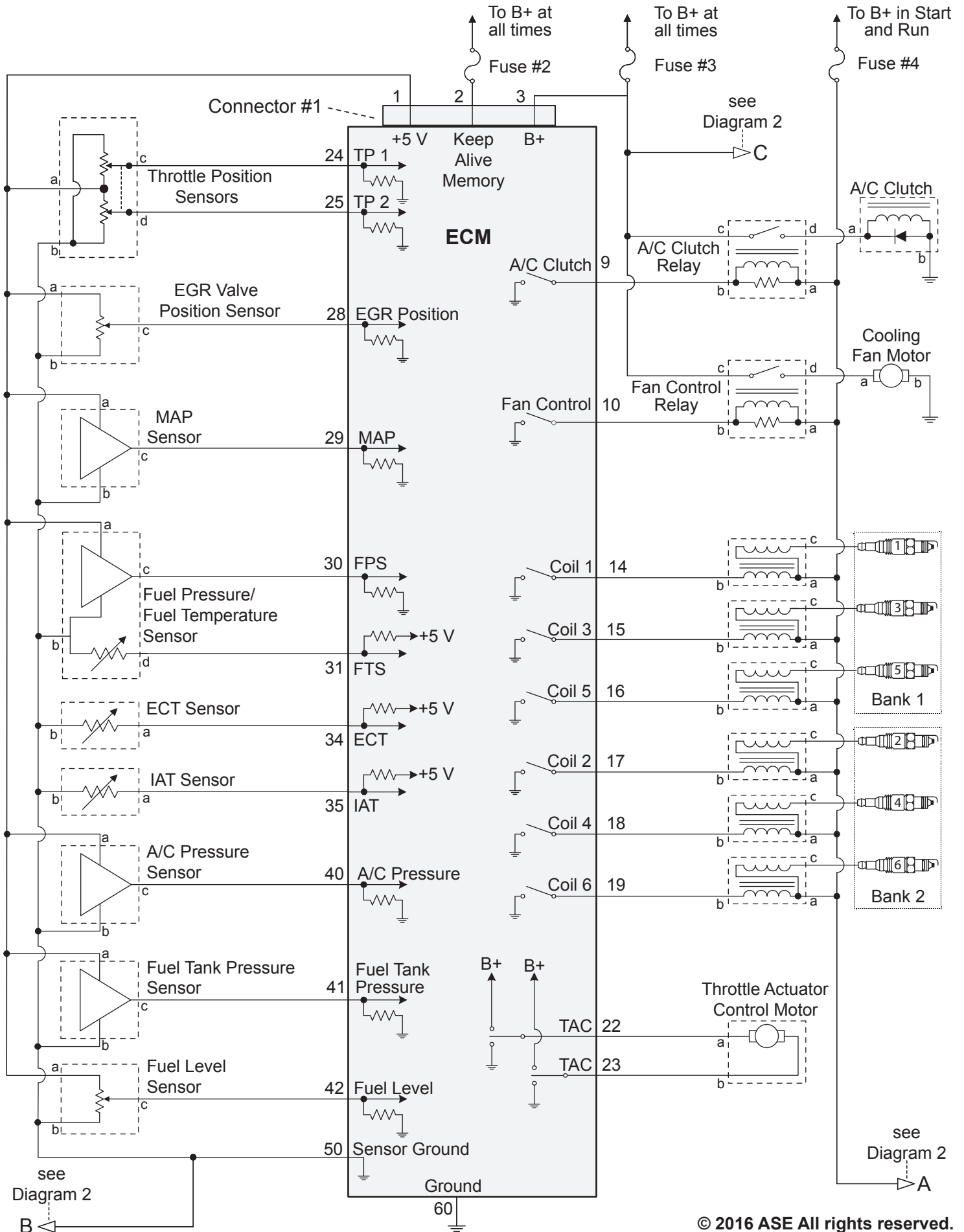

## Electrical Diagram 2 of 4

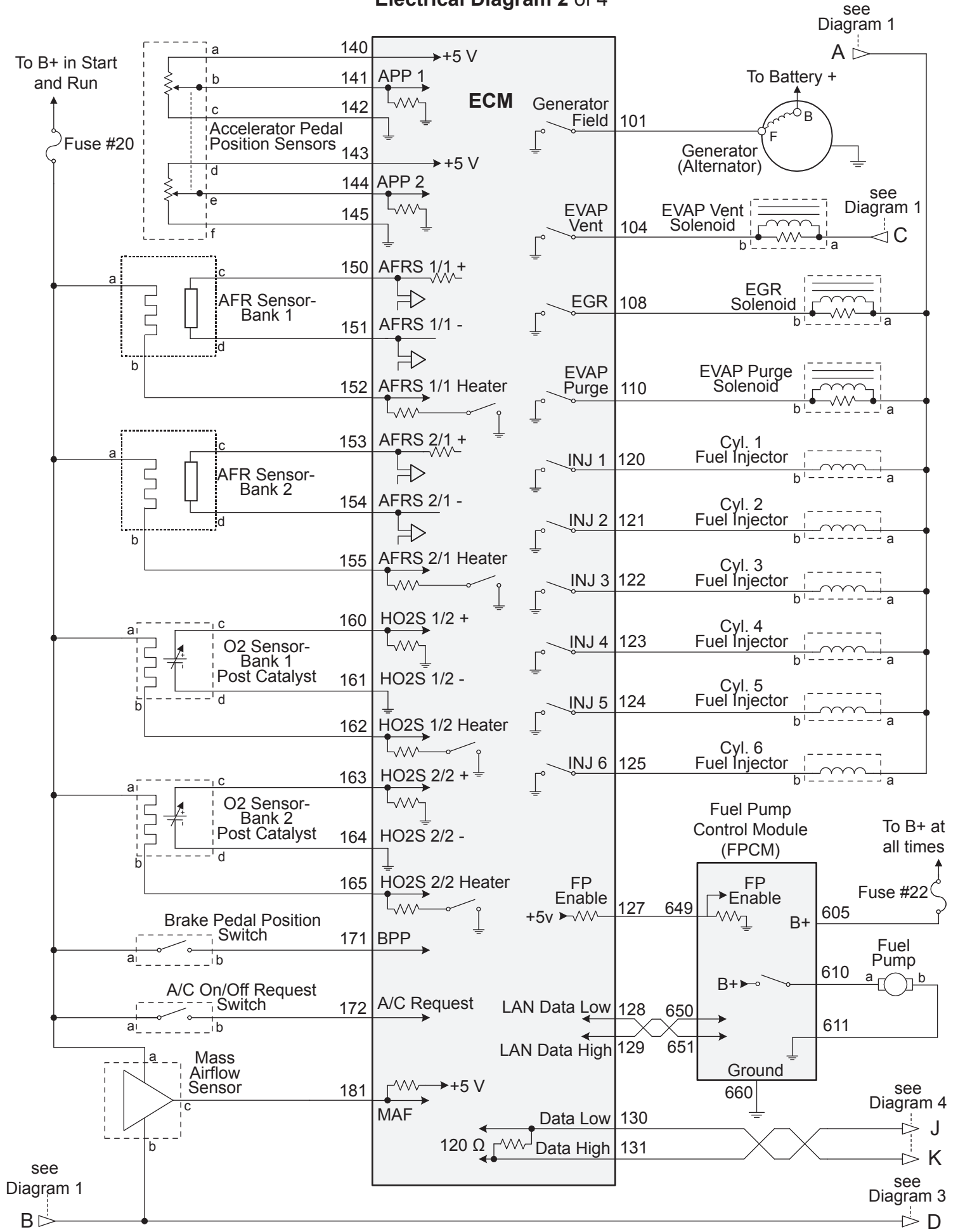

### Electrical Diagram 3 of 4

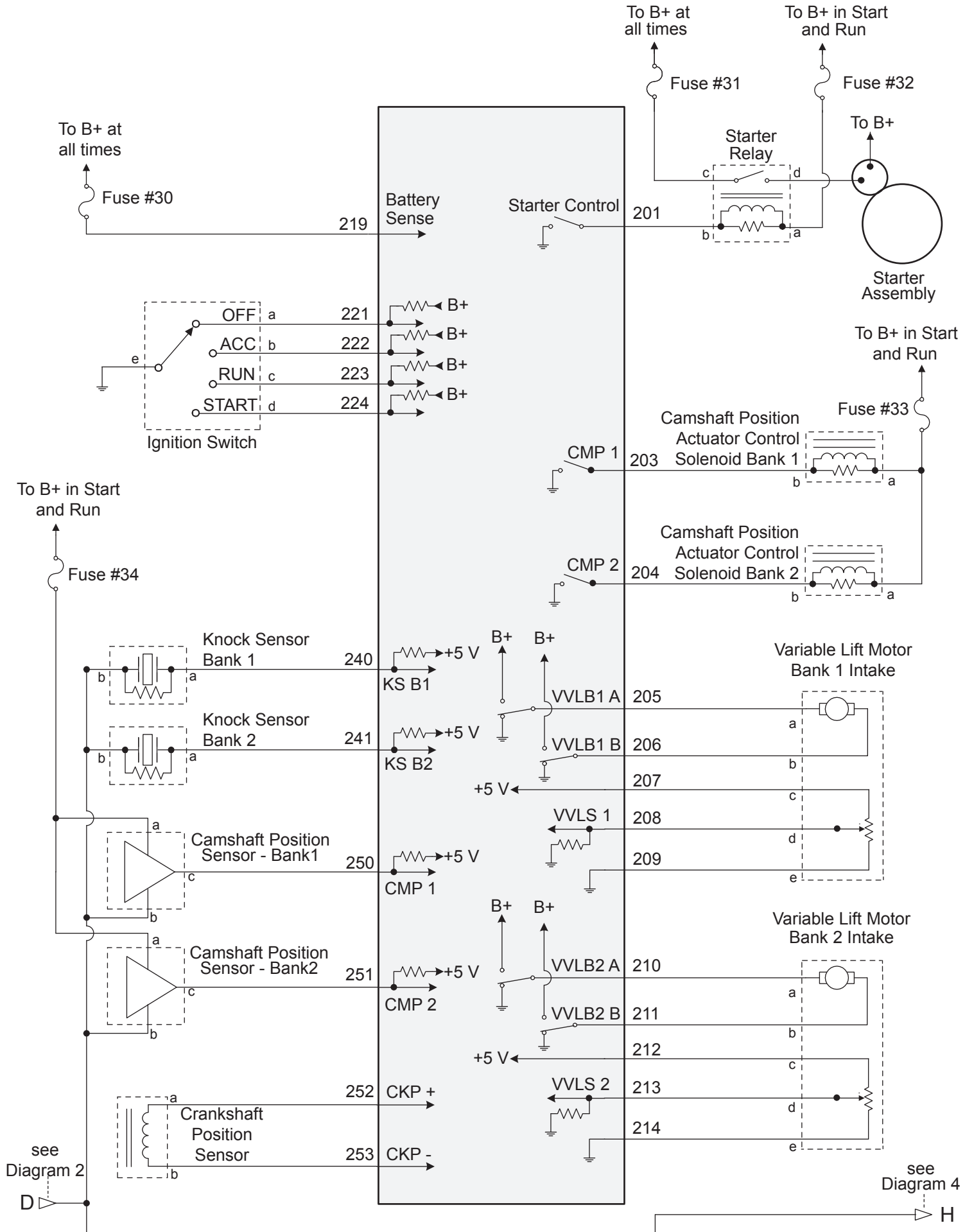

# Electrical Diagram 4 of 4

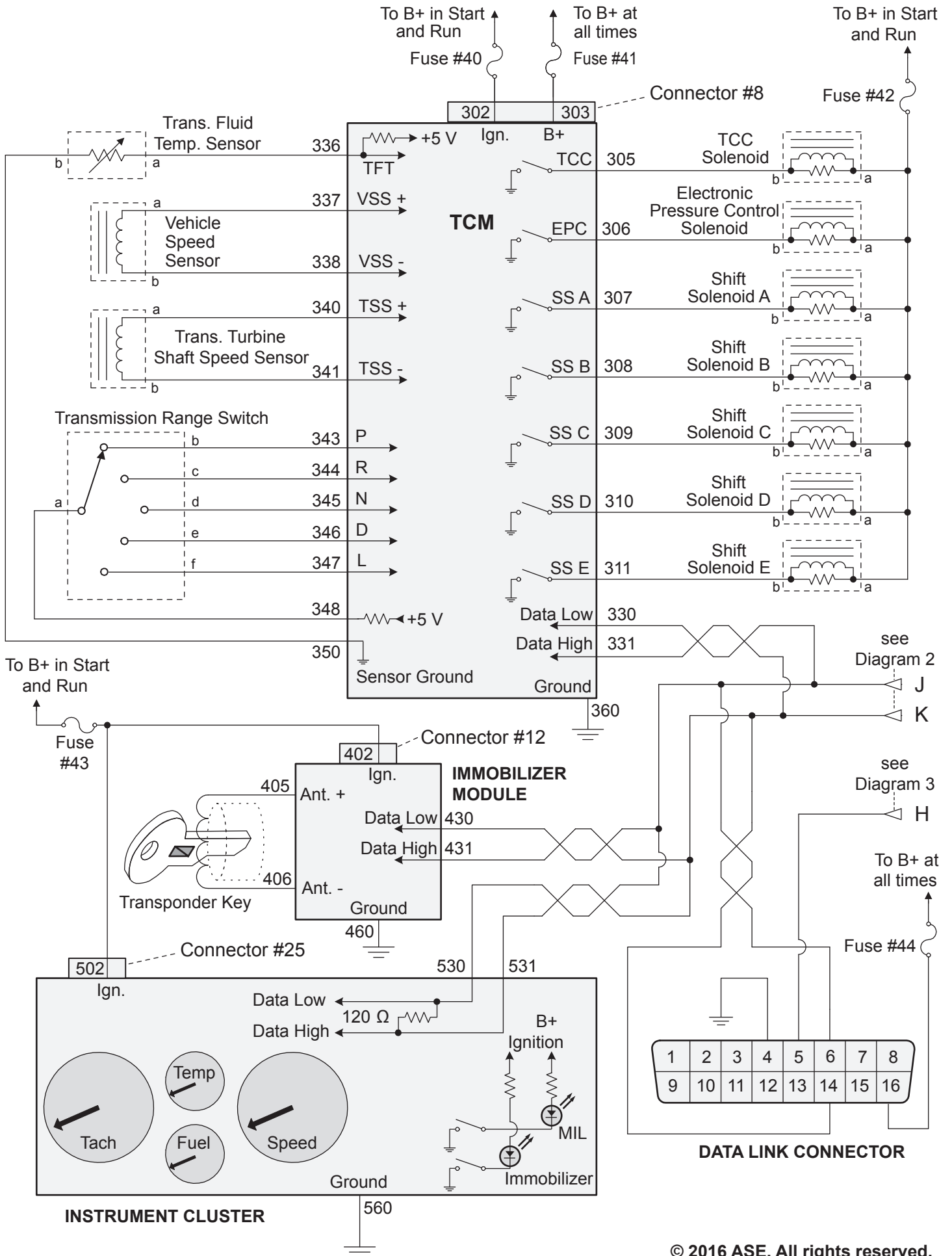

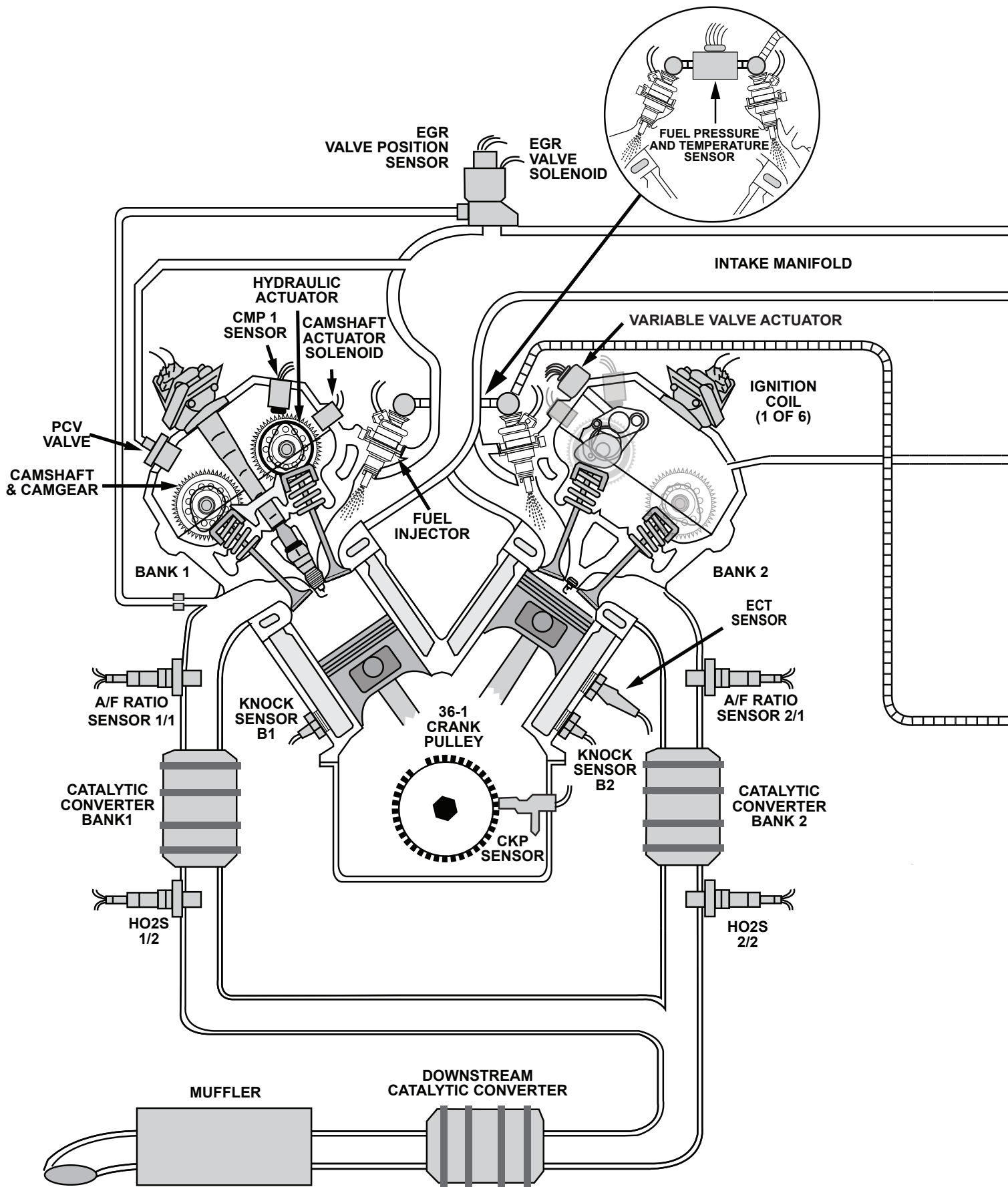

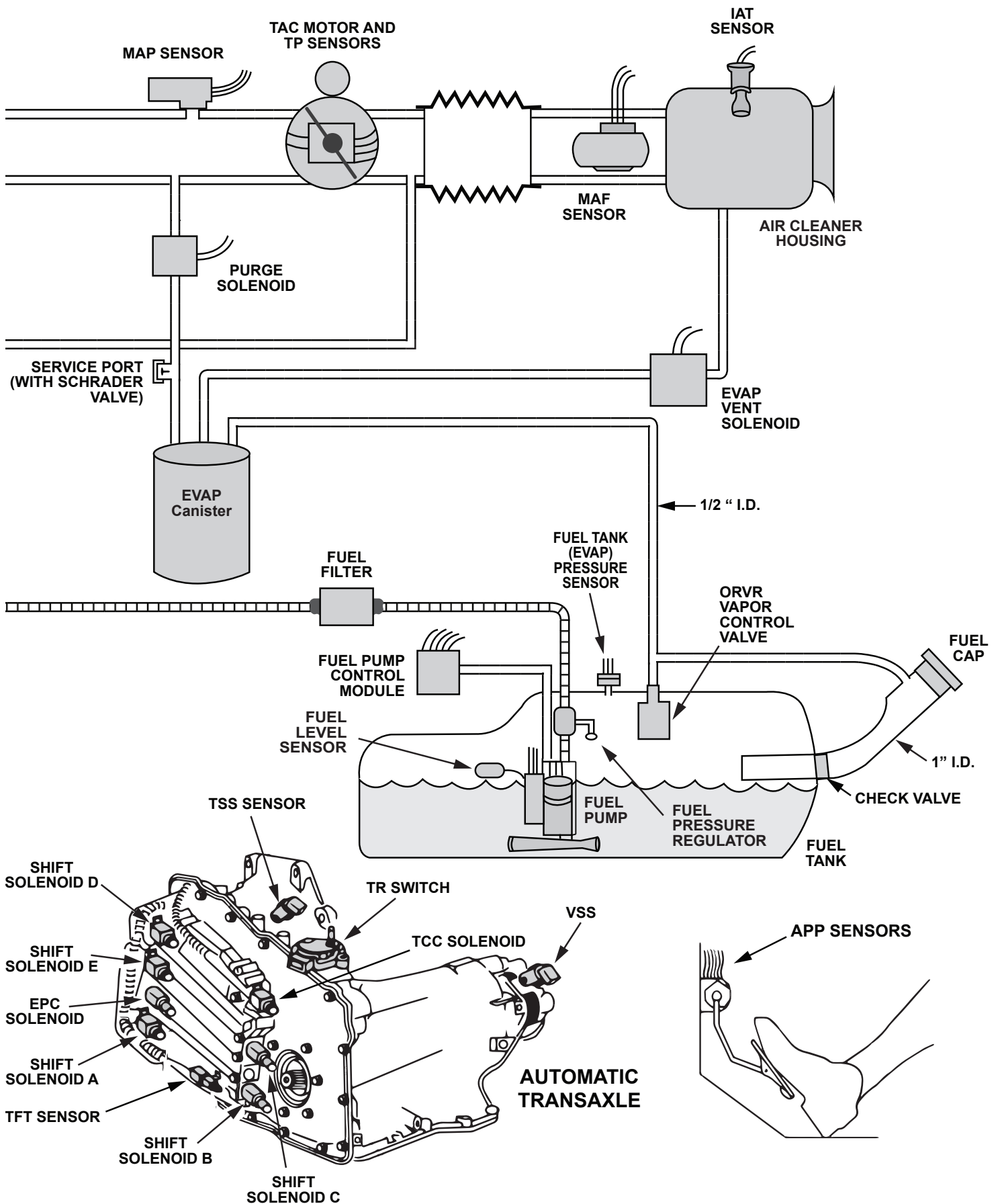



©2016 by the National Institute for **AUTOMOTIVE SERVICE EXCELLENCE (ASE)**  
All rights reserved

101 Blue Seal Dr. S.E., Suite 101, Leesburg, VA 20175 • (703) 669-6600 • [www.ase.com](http://www.ase.com)  
V.1 Revised January 1, 2016

**Prometric Inventory Code:**



P7012